

INSTRUCTIONS FOR USE

Nimbus 4 Nimbus Professional



WARNING

To avoid injury, always read this Instructions for Use and accompanied documents before using the product.



Mandatory to read the Instructions for Use

Design Policy and Copyright

® and ™ are trademarks belonging to the Arjo group of companies.

© Arjo 2019.

As our policy is one of continuous improvement, we reserve the right to modify designs without prior notice. The content of this publication may not be copied either whole or in part without the consent of Arjo.

Contents

General Safety	iii
Introduction	1
About this Manual	1
Intended use	1
About Nimbus 4 and Nimbus Professional	1
Nimbus Pump	2
Nimbus 4 Mattress	3
Mattress CPR and Transport Controls	3
Nimbus Professional Mattress	4
Clinical Applications	5
Indications	5
Contraindications	5
Cautions	5
Care of the patient when sitting	5
Installation	6
Preparing the System for Use	6
Installing the Mattress	6
Installing the Pump	7
Testing the Power Fail Alarm	8
Connecting the Tubeset	9
Disconnecting the Tubeset	9
System Operation	9
Controls, Alarms and Indicators	10
Pump Controls	10
Pump Indicators	11
Operation	13
Installing the System	13
Inflating the Mattress	13
Comfort Control	14
Operating Modes	14
Shut Down	14
Mattress Vent Valves	14
Guidelines for Selecting Mattress Vent Valves to Open	15
Transport Control	16
Deflating the Mattress	16
CPR Control	17
Nimbus Professional Mattress: Patient Positioning Guide	18
General	19
Supine Position (face up)	19
Prone Position (face down) - Not for Homecare Environment	20

Decontamination	21
Routine Maintenance	23
Nimbus 4 and Nimbus Professional Systems	23
Nimbus Pump	23
Nimbus 4 and Nimbus Professional Mattresses	23
Serial Number Labels	23
Troubleshooting and Alarm Conditions	24
Technical Specification	26
Electromagnetic Compatibility (EMC)	30

General Safety

Before you connect the system pump to a mains socket, read carefully all the installation instructions contained within this manual.

The system has been designed to comply with regulatory safety standards including:

- EN60601-1:2006/A1:2013 and IEC 60601-1-1:2005/A1:2012.
- EN60601-1-11:2010; IEC 60601-1-1-11:2010 and IEC60601-1-8:2012.
- ANSI/AAMI ES 60601-1(2005)+AMD(2012) and CAN/CSA-C22.2 No.60601-1(2008)+ (2014).

Safety Warnings

- **It is the responsibility of the care giver to ensure that the user can use this product safely.**
- **Whilst the patient is unattended, the decision to use safety sides should be based on clinical assessment and in line with local policy.**
- **Alignment of the bed frame, safety sides and the mattress should leave no gap wide enough to entrap a patient's head or body, or to allow egress to occur in a hazardous manner where entanglement with the mains power cable and tubeset or air hoses may result. Care should be exercised to prevent occurrence of gaps by compression or movement of the mattress. Death or serious injury may occur.**
- **Make sure that the mains power cable and tubeset or air hoses are positioned to avoid causing a trip or other hazard, and are clear of moving bed mechanisms or other possible entrapment areas. The mains power cable of this pump is designed to allow movement of the bed, and should be fitted into the cable management flaps along the sides of the mattress, as described in this manual.**
- **Electrical equipment may be hazardous if misused. There are no user-serviceable parts inside the pump. The pump's case must only be removed by authorised technical personnel. No modification of this equipment is allowed.**
- **The mains power socket/plug must be accessible at all times. To disconnect the pump completely from the electricity supply, remove the plug from the mains power socket.**
- **The CPR control and/or the CPR indicator tag must be visible and accessible at all times.**
- **Disconnect the pump from the mains power socket before cleaning and inspecting.**
- **Keep the pump away from sources of liquids and do not immerse in water.**
- **Do not use the pump in the presence of uncontained flammable liquids or gasses.**
- **The cover of this product is vapour permeable but not air permeable and may present a suffocation risk.**
- **Do not use the mattress without a cover, it provides a protective barrier.**
- **Bags supplied with this equipment may present a suffocation risk; to avoid the risk of suffocation keep the bags away from babies and small children.**
- **When not fitted to a bed, the bed hooks on the pump may present a hazard to small children. Store the pump in a safe place.**
- **Only the pump and mattress or seat combination as indicated by Arjo should be used. The correct function of the product cannot be guaranteed if incorrect pump and mattress or seat combinations are used.**
- **If a serious incident occurs in relation to this medical device, affecting the user, or the patient then the user or patient should report the serious incident to the medical device manufacturer or the distributor. In the European Union, the user should also report the serious incident to the Competent Authority in the member state where they are located.**

Precautions

For your own safety and the safety of the equipment, always take the following precautions:

- Placing extra layers between the patient and the mattress potentially reduces the benefits provided by the mattress and should be avoided or kept to a minimum. As part of sensible pressure area care, it is advisable to avoid wearing clothing which may cause areas of localised high pressure due to creases, seams, etc. Creases in the top cover and placing objects in pockets should be avoided for the same reason.
- Do not expose the system, especially the mattress, to naked flames, such as cigarettes, etc.
- In the event of a fire, a leak in the seat or mattress could propagate the fire.
- Do not use or store the system in direct sunlight.
- Do not use phenol-based solutions to clean the system.
- Make sure the system is clean and dry prior to use or storage.
- Never use sharp objects or electrically heated under blankets on or under the system.
- Store the pump and mattress in the protective bags supplied.
- Pets and children must be supervised in the vicinity of the system.
- Always make sure the drag handles are fastened to the base cover, when the patient is NOT being transported.
- When the pump is in use the operator should remain in the area in case the system alarms.

Electromagnetic Compatibility (EMC)

This product complies with the requirements of applicable EMC Standards. Medical electrical equipment needs special precautions regarding EMC and needs to be installed in accordance with the following instructions:

- The use of accessories not specified by the manufacturer may result in increased emissions by, or decreased immunity of, the equipment, affecting its performance.
- Portable and mobile radio frequency (RF) communications equipment (e.g. mobile/cell phones) can affect medical electrical equipment.
- If this equipment needs to be used adjacent to other electrical equipment, normal operation must be checked before use.
- For detailed EMC information contact Arjo service personnel.

Expected Service Life

The Nimbus® pump has an expected service life of seven years. To maintain the condition of the pump, have the pump serviced regularly according to the schedule recommended by Arjo.

Do NOT use unapproved accessories or attempt to modify, disassemble or otherwise misuse the *Nimbus 4* and *Nimbus Professional* system. Failure to observe this caution could result in injury, or in extreme cases, death.

End of Life Disposal

- Fabric material used on the mattresses or any other textiles, polymers or plastic materials etc. should be sorted as combustible waste.
- Mattresses at the end of life should be disposed of as waste according to the national or local requirements which may be landfill or combustion.
- Pump units have electrical and electronic components should be disassembled and recycled per Waste of Electrical and Electronic Equipment (WEEE) or in accordance with local or national regulation.

1. Introduction

About this Manual

This manual is your introduction to the *Nimbus 4* and *Nimbus Professional* systems. You must read and fully understand this manual before using the system.

Use this manual to initially set up the system, and keep it as a reference for day-to-day routines and as a guide to maintenance.

If you have any difficulties in setting-up or using the *Nimbus 4* and *Nimbus Professional* systems, contact your local Arjo sales office, listed at the end of this manual.

Intended use

The intended use of this product is to prevent and/or manage pressure ulcers for patients up to 250 kg (550 lb).

The *Nimbus 4* and *Nimbus Professional* systems should be used as part of a prescribed plan of care (refer to “Indications” on page 5).

About *Nimbus 4* and *Nimbus Professional*

Nimbus 4 and *Nimbus Professional* are highly effective Dynamic Flotation Systems providing active therapy for the prevention and management of pressure ulcers.

The systems consist of a pump and mattress replacement. The support system can be used on hospital beds and domestic beds in acute care, long-term care and homecare environments, including private homes. Beds with divided sections for independent elevation of a patient's head and/or knees can be adjusted with these mattresses in position.

Both systems use the same *Nimbus* pump, which has two operating modes:

- Dynamic mode that cycles the support surface beneath the patient every 10 minutes providing periods of pressure relief for the whole body.
- Static mode where the support surface remains constant (all cells equally inflated).

The *Nimbus Professional* mattress combines all the qualities of the *Nimbus* range of mattresses with the added benefit of optional head cell deflate; this will assist the clinician with a range of nursing procedures including prone nursing, intubation, neck cannulation and hygiene, while the body of the mattress continues to provide optimal alternating pressure redistribution.

Both mattresses have been designed with specialised Vent Valves, so that some of the cells (including the three head cells on the *Nimbus Professional* mattress) can be selectively deflated to assist with pressure area care and patient management.

The mattresses incorporate an advanced AutoMatt[®] sensor pad which ensures the patient is automatically supported at optimum pressures regardless of size, height, position or weight distribution.

Both mattresses incorporate the five Heelguard[®] cells at the foot end of the mattress which ensure that the patient's heels are provided with the maximum pressure relief.

If cardiac arrest occurs, the mattresses can be rapidly deflated using the CPR (Cardio-Pulmonary Resuscitation) control to allow cardiac resuscitation procedures to be performed.

A full technical description of the *Nimbus 4* and *Nimbus Professional* system can be found in the Service Manual, part No. SER0007, available from Arjo.

Nimbus Pump

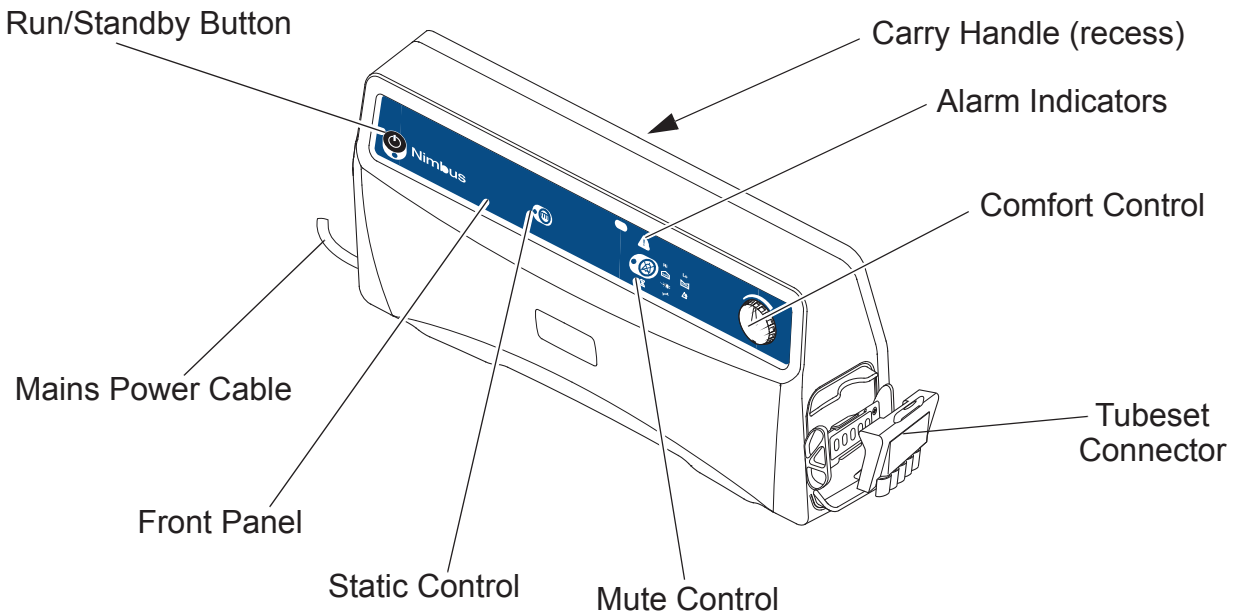

Nimbus 4 Mattress

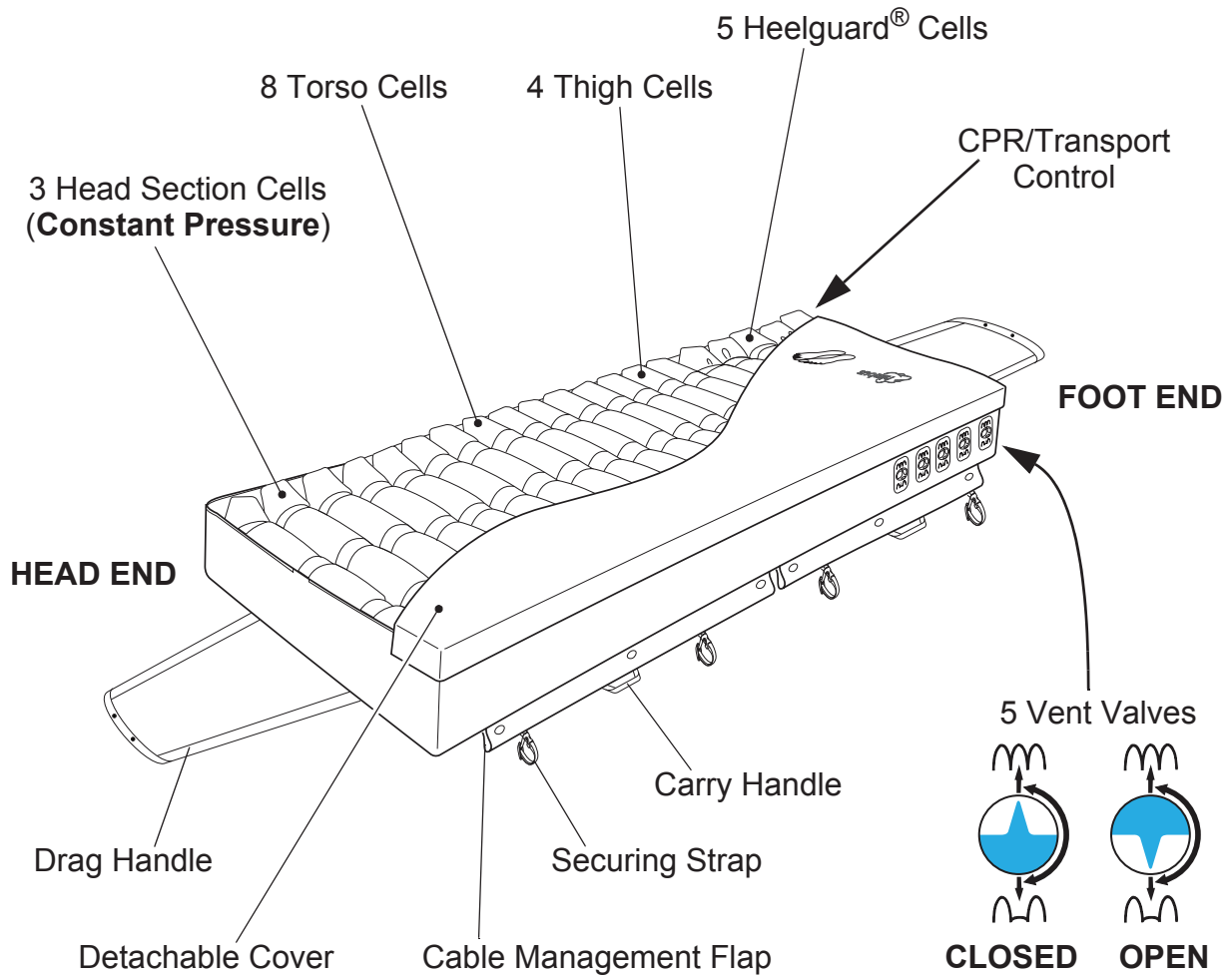

Mattress CPR and Transport Controls

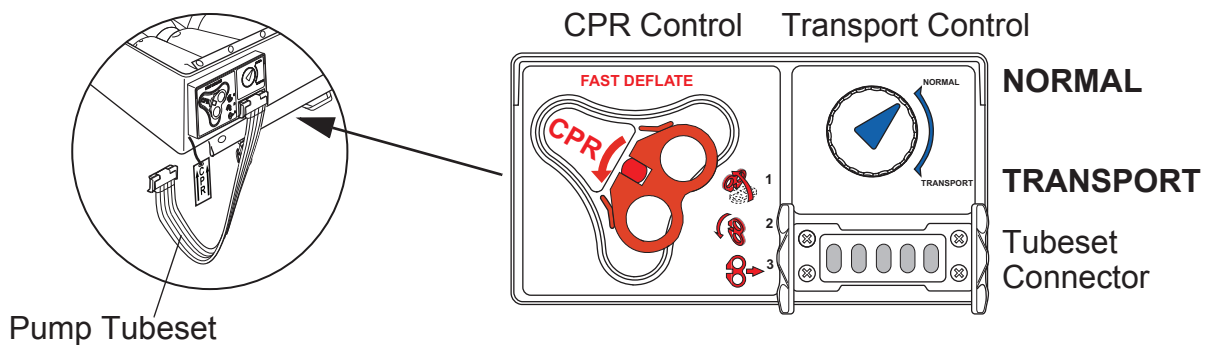

NOTE

These controls are common to both Nimbus 4 and Nimbus Professional mattresses, and are located at the foot end of the mattress on the opposite side to the Vent Valves.

Nimbus Professional Mattress

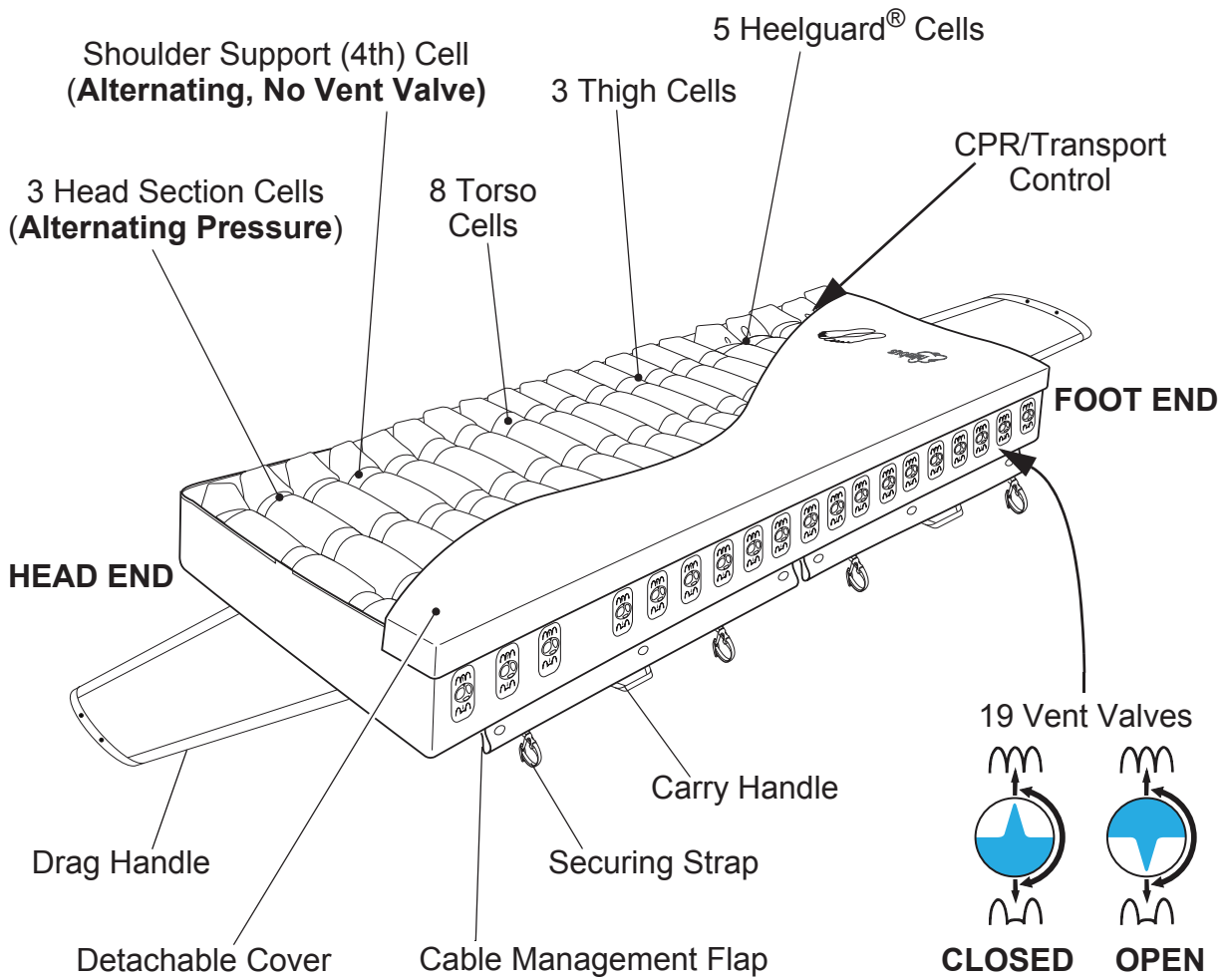

NOTE

The drag handles enable transportation of a patient in case of emergency. This is the only situation the drag handles can be unfastened. In any other situation the drag handles must be fastened to the base cover in order to remove the risk of tripping.

2. Clinical Applications

Indications The *Nimbus 4* and *Nimbus Professional* systems are indicated for the prevention and/or management of all categories¹ of pressure ulcer, when combined with an individualised, comprehensive pressure ulcer protocol: for example, repositioning, nutritional support, skin care. Selection should be based upon a holistic assessment of the patient's individual care needs.

These systems represent one aspect of a pressure ulcer management protocol; all other aspects of care should be considered by the prescribing clinician.

If existing wounds do not improve or the patient's condition changes the overall therapy regimen should be reviewed by the prescribing clinician.

The above are guidelines only and should not replace clinical judgement.

The *Nimbus 4* and *Nimbus Professional* mattress is designed for patients weighing up to 250 kg (550 lb).

Contraindications Do not use *Nimbus 4* and *Nimbus Professional* systems for patients with unstable spinal fractures.

Cautions If patients have other unstable fractures, or conditions which may be complicated by a soft or moving surface, advice should be sought from an appropriate clinician before use.

While the *Nimbus 4* and *Nimbus Professional* systems have been designed to manage patients up to the weight limits indicated above, those approaching this upper limit are likely to have additional care and mobility needs and may be better suited to a specialist bariatric system.

Active therapy (alternating) cushions may be unsuitable for patients with poor sitting posture or pelvic deformity; advice from a seating specialist should be sought.

Care of the patient when sitting Seated patients are at increased risk of pressure ulcers particularly if they are immobile or have wounds over the seating area. For optimal outcome, provide a pressure redistributing seat cushion in a chair which promotes a good sitting posture and has a level base seat to support the cushion, in addition to an individual repositioning programme.

NOTE

Mattress and cushion combinations may have different upper weight limits.

NOTE

Cushions should be used in combination with pressure-redistributing mattresses to provide 24-hour therapy.

1. NPUAP/EPUAP International Pressure Ulcer Guideline, 2014.

3. Installation

The *Nimbus 4* and *Nimbus Professional* systems are simple to install using the following guidelines.

NOTE

Refer to Section 4, Page 10 “Controls, Alarms and Indicators” for a comprehensive description of the controls and indicators on the pump.

Preparing the System for Use

Remove the system from the packaging. You should have the following items:

- *Nimbus* pump, with integral bed bracket.
- Mains power cable (pump).
- *Nimbus 4* mattress replacement or *Nimbus Professional* mattress replacement with covers. Do not use the mattress without a cover.
- Tubeset.

Installing the Mattress

1. Remove the conventional mattress from the bed frame and check that there are no protruding bed springs or sharp objects on the bed frame surface.

NOTE

Heavily ridged bed baseboards may require special considerations for correct system operation - consult your Arjo sales office.

2. Unroll the mattress onto the bed base and make sure that the CPR control is at the foot end, and the CPR label is hanging freely.
3. Attach the mattress to the bed frame using the new fastener straps, as shown. These eight fastener straps can be moved to any of the 10 anchor points on the base of the mattress, to allow for attaching the mattress to different types of bed frame.

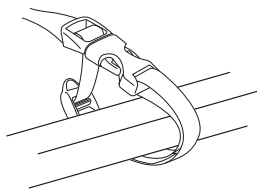

NOTE

If the bed has divided sections for independent elevation of a patient's head and/or knees, attach the mattress to the movable parts of the bed frame only.

NOTE

Secure drag handles by fastening them to the base cover.

4. To make sure that the pressure relieving properties are not impaired, the mattress cover must not be pulled tight and covering sheets should fit loosely.

5. Make sure that **ALL** the Vent Valves are closed:

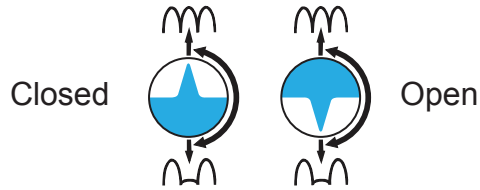

6. Make sure the CPR control is closed and locked in position and the Transport control is set to NORMAL.

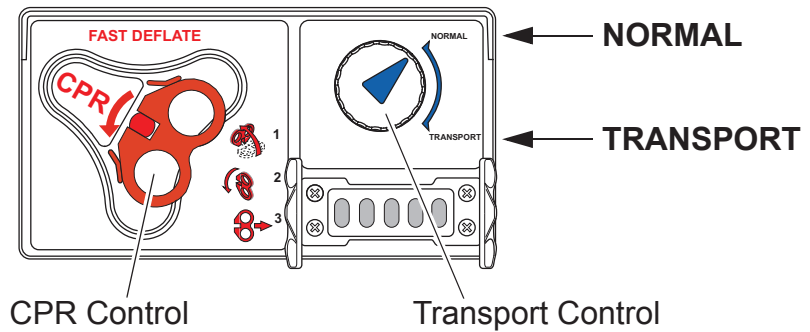

Installing the Pump

1. If the pump is to be hung from the end of the bed, make sure that the bed bracket is securely attached to the pump, and then attach the pump and bed bracket to the bed frame.

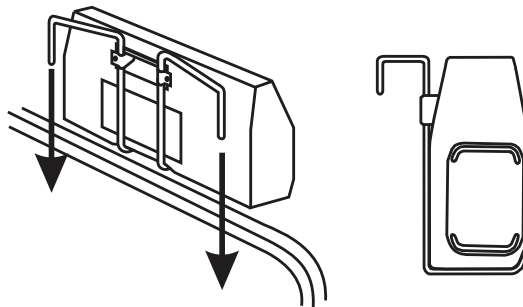

2. Alternatively the pump can be placed underneath the bed, either upright or lying on its back.
3. Insert one end of the mains power cable into the receptacle on the pump.
4. Connect the other end of the mains power cable into a suitable mains power outlet.

Cable Management

In order to prevent a trip hazard, the mains power cable should be put through one of the cable management flaps which are on each side of the mattress base cover, as follows:

1. Locate one of the cable management flaps.
2. If necessary, open the press studs along the flap.

3. Run the mains power cable along the side of the mattress securing the flap round the cable using the press studs.

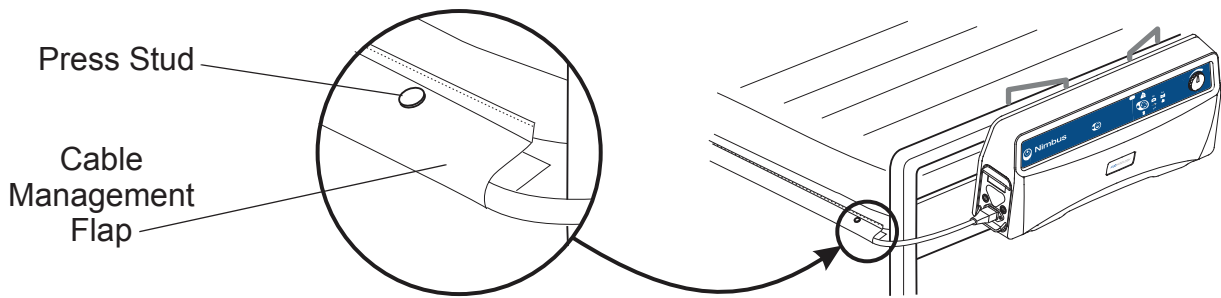

Testing the Power Fail Alarm

The Power Fail Alarm is powered by an internal rechargeable battery. The duration of the alarm will depend on the level of charge in the battery, which also depends on the age and condition of the battery.

- The battery has a service life of between five to seven years. It is not user replaceable and must be replaced as part of the service procedure.

It is recommended that the alarm is tested when the pump is installed, as follows:

NOTE

Refer to Section 4, Page 10 "Controls, Alarms and Indicators" for a comprehensive description of the controls and indicators on the pump.

1. Connect the pump to the mains power supply, and press the Run/Standby button on the pump to put the pump in the Run mode. Allow it to run for 10-15 seconds.
2. Remove the mains power at the wall socket without putting the pump into Standby first.
3. The power fail alarm operates within 10 seconds, as follows:
 - The yellow Alarm triangle illuminates.
 - The Power indicator illuminates.
 - An audible warning sounds.
4. The alarm continues until:
 - The mains power is resumed.
 - You press and hold the Run/Standby button to put the pump into Standby.
5. If the alarm does not operate, run the pump for approximately four hours to recharge the battery.
6. Retest the alarm after the battery has been recharged. Allow the alarm to operate for approximately two minutes to ensure that it has been adequately recharged.

7. If the alarm does not operate for two minutes, call the service engineer.

NOTE

If the Power Fail Alarm does not operate after this test and a service engineer has been called, the pump can continue to be used with regular checks of the Power-On status. All other alarms continue to function as normal.

Connecting the Tubeset

To connect the tubeset to the mattress and pump:

1. Locate the bottom of the tubeset connector onto the bottom of the pump/mattress connector.
2. Pull the top of the tubeset connector up and over the top of the pump/mattress connector, until the tubeset connector “clicks” into position.
3. Make sure both connections are secure.

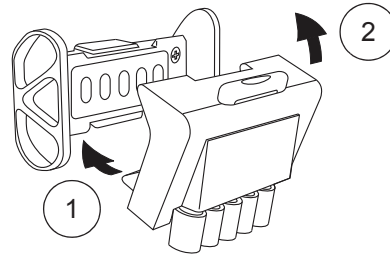

Disconnecting the Tubeset

To disconnect the tubeset from the mattress and pump:

1. Move the tubeset connector down by pulling the tubeset extrusion downwards, and then pull the bottom of the tubeset connector away from the bottom of the pump/mattress connector.
2. Lift the top of the tubeset connector from the top of the pump/mattress connector.

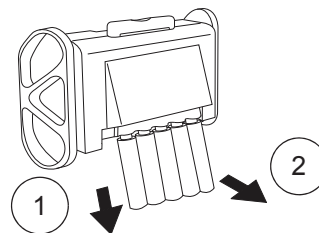

System Operation

The system is now ready for use. Refer to Section 4, Page 10 “Controls, Alarms and Indicators” and Section 5, Page 13 “Operation” for day-to-day operating instructions.

4. Controls, Alarms and Indicators

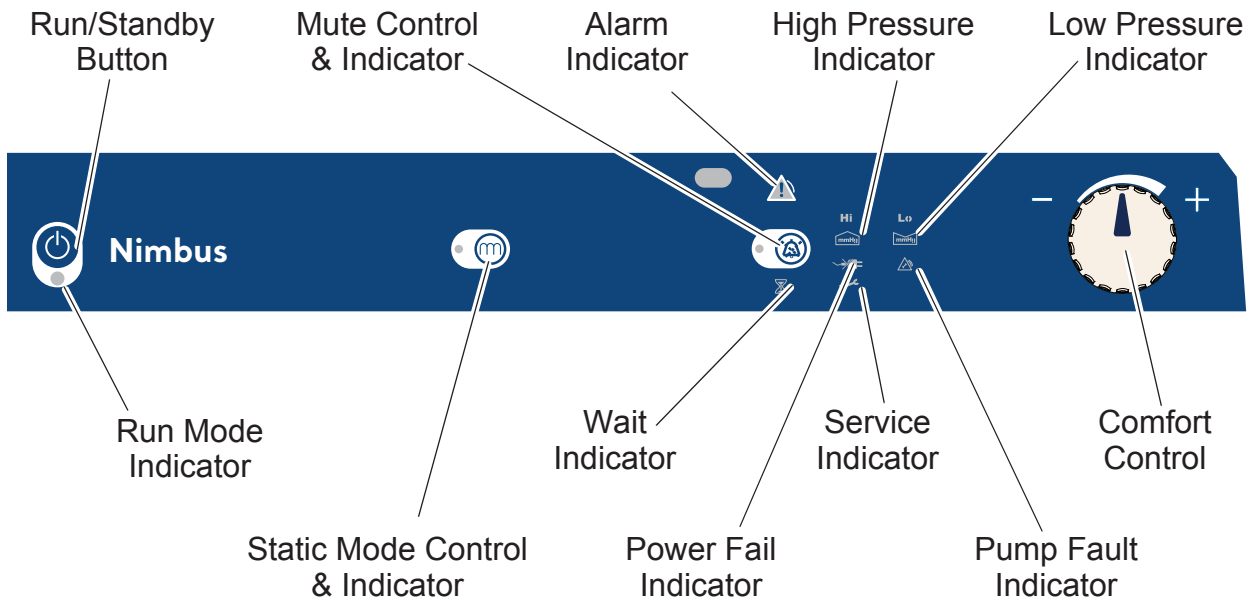

Pump Controls

The pump front panel has the following controls:

Run/Standby Button



Press the Run/Standby button to put the pump into the Run mode; the Run indicator will change to green.

To put the pump into Standby, press and hold the Run/Standby button for approximately 3 seconds; this prevents accidental operation. The Run indicator will be extinguished.

Static Mode



Selects the operating mode, either Static or Dynamic. When the pump is first powered up, its default setting is Dynamic mode. To switch to Static mode, press and hold the Static Mode button for a minimum of 3 seconds. Static mode is confirmed by the illumination of the button's yellow indicator.

To return to Dynamic mode, press and hold the button for a minimum of 3 seconds. Dynamic mode is confirmed by the extinguishing of the button's yellow indicator.

Alarm Mute



An Alarm Mute button is provided to silence warning sounds during an alarm condition. Press and hold the Alarm Mute button for a minimum of 3 seconds to mute any alarms.

Alarm Mute is confirmed by the illumination of the button's yellow indicator.

NOTE

The Alarm Mute button does not operate in a Power Fail condition.

Comfort Control

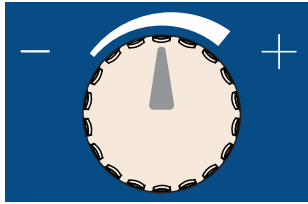

The *Nimbus 4* and *Nimbus Professional* systems automatically compensate for patient weight distribution and position, to optimise the mattress pressure relieving performance. However, the mattress cell pressure can be manually adjusted for patient comfort using the rotary Comfort Control.

Turn the Comfort Control clockwise for a firmer setting and counterclockwise for a softer setting.

Pump Indicators

The pump front panel has the following indicators:

Run Mode

The green Run indicator below the Run/Standby button is illuminated to confirm the pump is in Run mode.

Static Mode

The yellow indicator on the Static button is illuminated when Static mode has been selected for operation.

Alarm Mute

The yellow indicator on the Mute button is illuminated when an audible alarm has been silenced.

NOTE

The Alarm Mute button does not operate in a Power Fail condition.

Wait



The Wait indicator is illuminated when the mattress is being inflated.

NOTE

The indicator will remain illuminated until the mattress has been fully inflated.

High Pressure



The High Pressure indicator is illuminated whenever the pump detects high pressure within the mattress.

If this condition occurs, the air supply from the pump is switched off until normal pressure is detected. After two seconds of normal pressure being detected the indicator is switched off and the air supply restarted.

Low Pressure



The Low Pressure indicator is illuminated whenever the pump detects low pressure within the mattress.

This may indicate that there is insufficient pressure to support a patient or that the Transport control is turned to the Transport position whilst the pump is on and connected to the mattress.

The Low Pressure indicator will be switched off once normal pressure is reached.

Alarm



The pump unit incorporates a sophisticated alarm detection system that differentiates between patient movement and genuine alarm conditions.

Whenever an alarm condition is detected, the yellow Alarm triangle illuminates together with an indicator of the cause of the alarm. Additionally, an audible warning will sound, which can be

temporarily silenced by pressing the Alarm Mute button for a minimum of 3 seconds (Refer to “Alarm Mute” on page 10).

The triangular Alarm symbol is displayed with one or more of the following indicators:

- Low Pressure (refer to “Low Pressure” on page 11).
- High Pressure (refer to “High Pressure” on page 11).
- Pump Fault (refer to “Pump Fault” on page 12).
- Power (refer to “Power Fail” on page 12).

NOTE

For all alarm conditions except Power Fail, once the alarm condition has been detected and displayed, it can only be cancelled by pressing and holding the Run/Standby button to put the pump into Standby.

Refer to Section 9, Page 24 “Troubleshooting and Alarm Conditions” for possible causes of the above alarm conditions.

Pump Fault



The Pump Fault indicator is illuminated when an internal pump malfunction is detected.

The fault can only be rectified by carrying out a service on the pump.

Power Fail



The Power indicator will illuminate when a mains power failure has been detected.

The alarm will continue until:

- The mains power is resumed, or
- You press and hold the Run/Standby button to put the pump into Standby.

The Power Fail Alarm is powered by a rechargeable battery. The duration of the alarm will depend on the level of charge in the battery. The battery may have become discharged or reached the end of its life; it is therefore recommended that the alarm is tested before the pump is used (refer to “Testing the Power Fail Alarm” on page 8).

NOTE

If the Power Fail Alarm does not operate after this test and a service engineer has been called, the pump can continue to be used with regular checks of the Power-On status. All other alarms will continue to function as normal.

Service Indicator



The Service Indicator symbol will be illuminated after a set number of running hours to indicate that the pump is ready for a service. This service period is set to 12 months run time.

NOTE

The pump will continue to operate normally even when the Service Indicator symbol is illuminated.

5. Operation

These instructions cover day-to-day operation of the system. Other operations, such as maintenance and repair, should only be carried out by suitably qualified personnel.

NOTE

Refer to Section 4, Page 10 “Controls, Alarms and Indicators” for a comprehensive description of the controls and indicators on the pump.

WARNING

DO NOT PLACE THE PATIENT ON THE MATTRESS UNTIL IT IS FULLY INFLATED AND NORMAL OPERATING PRESSURE HAS BEEN REACHED.

Installing the System

Before using the *Nimbus 4* or *Nimbus Professional* system make sure that it has been installed correctly in accordance with Section 3, Page 6 “Installation”.

- The CPR unit on the mattress is closed and locked in position.
- The Transport control on the mattress is set to Normal.
- ALL Vent Valves on the mattress are closed.

Inflating the Mattress

1. Connect the pump to the mains power supply using the supplied cable and press the Run/Standby button to put the pump into the Run mode; the Run indicator will change to green.
2. The pump runs a self test for approximately three seconds then all the indicators on the front panel are illuminated.
3. When normal operating pressure has been reached, both the Low Pressure and Wait lights will extinguish.

NOTE

It may take up to 15 minutes to inflate the mattress. However, at the lower end of the operating temperature range, it may take longer to inflate. Always wait until both the Low Pressure and Wait indicators have been extinguished.

4. Place the patient on the mattress in the supine (face up) position. Refer to Section 6, Page 18 “Nimbus Professional Mattress: Patient Positioning Guide”.

NOTE

If the operation of the pump changes during use, refer to Section 9, Page 24 “Troubleshooting and Alarm Conditions” before calling a service engineer or contacting your local Arjo sales office.

Comfort Control Adjust the Comfort Control to the patient's requirements.

Operating Modes The system has two operating modes:

- Dynamic mode provides the optimum pressure relieving performance and should be used in most cases. In Dynamic mode the support surface beneath the patient is cycled every 10 minutes.
- Static mode provides a stable, non-moving support surface (all cells are equally inflated).

The pump defaults to the Dynamic operating mode when first powered up.

Select the required operating mode.

NOTE

When changing between operating modes, the patient's monitoring and repositioning program should be reviewed.

Shut Down Put the pump into Standby, by pressing and holding the Run/ Standby button for a minimum of 3 seconds; the Run indicator will be extinguished.

- If the pump needs to be completely isolated from the mains power supply, remove the plug from the mains power socket.

Mattress Vent Valves On the *Nimbus 4* and *Nimbus Professional* mattresses, the Vent Valves along the side of the mattress enable individual cells to be deflated:

1. *Nimbus 4* mattress has only five Vent Valves in the Heelguard section at the foot end of the mattress.
2. *Nimbus Professional* mattress:
 - The three Head Section cells have Vent Valves.
 - The eight Torso cells, three Thigh cells and five Heelguard cells have Vent Valves.
 - The single Shoulder Support (4th) cell has no Vent Valve and cannot be deflated.
3. During system operation, open individual Vent Valves on the Torso, Thigh and/or Heelguard[®] cells to deflate the cell and assist with pressure area care and patient management, including everyday interventions such as chest x-rays.

Nimbus Professional Mattress - Vent Valves

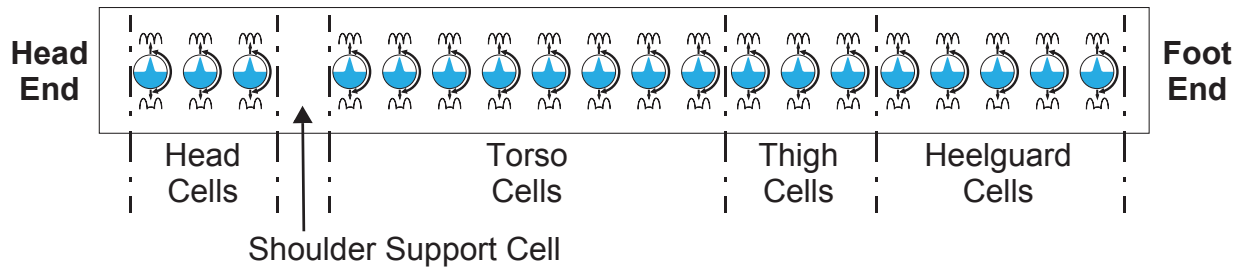

Guidelines for Selecting Mattress Vent Valves to Open

The following guidelines should be adhered to when selecting Vent Valves to open on the *Nimbus 4* and *Nimbus Professional* mattresses:

1. For permanent off-loading/pressure relief:
 - Select no more than one cell directly under the area you want to relieve (head, torso, calf or heel section).
 - Open the Vent Valve to deflate the cell.

NOTE

This single cell can be left permanently deflated.

2. For temporary nursing procedures:
 - Select one or more adjacent cells.
 - Open the Vent Valve(s) to deflate the cell(s).
 - Once the nursing/clinical procedure is complete re-inflate the cell(s) by closing the Vent Valve(s).

NOTE

Deflating more than one adjacent cell may affect the support of the patient during the normal alternating cycle, so should only be used for temporary procedures.

3. For complex patient needs, you can off-load more than one area on the patient for longer periods, but with the following restrictions:
 - Deflate only one cell in the torso section.
 - Deflate only one cell in the calf/heel section.
 - Deflate only one cell in the Head Section when the patient is in the supine (face up) position, or all three cells in the Head Section when the patient is in the prone (face down) position.

NOTE

Do not deflate any more cells in each area or it may affect the support of the patient during the normal alternating cycle.

Transport Control

This sets the mattress into Transport mode where the mattress is sealed and the support surface is equally pressurised; the pump and/or tubeset can then be removed. In this mode the mattress will support the patient for up to 12 hours.

To set Transport mode:

1. Turn the Transport control knob clockwise to Transport.
2. Put the pump into Standby and disconnect the tubeset.

NOTE

If the Transport control is set to Transport with the tubeset connected and the pump switched on, the pump will indicate a Low Pressure fault alarm.

To resume normal operation:

1. Re-connect the pump and tubeset to the mattress.
2. Turn the Transport control knob counterclockwise to Normal.
3. Put the pump into the Run mode.
4. Check the system is operating normally.

Deflating the Mattress

To deflate and store the mattress, do the following:

1. Put the pump into Standby, and disconnect the pump from the mains power supply.
2. Remove the tubeset from the pump and mattress.
3. Activate the CPR control to deflate the mattress.
4. Make sure the Transport control is set to Normal.
5. Fold the mattress over in the middle to assist in air evacuation; if necessary, gently press on the base cover to increase the air loss.
6. Roll up the mattress, starting at the foot end.

NOTE

Make sure the mattress is dry before rolling it up.

CPR Control

IMPORTANT

IN THE EVENT OF CARDIAC ARREST.

In the event of a patient suffering cardiac arrest and CPR needing to be administered:

To Activate the CPR 1. Lift the red CPR handle at the foot end of the mattress.

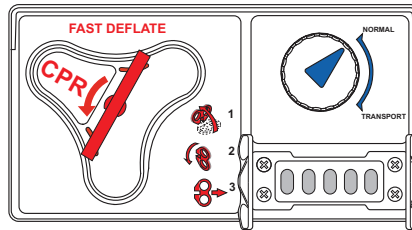
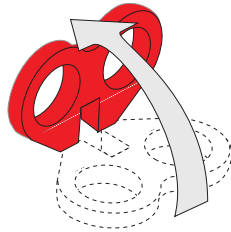

2. Turn the handle counterclockwise.

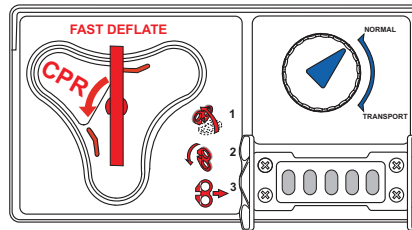
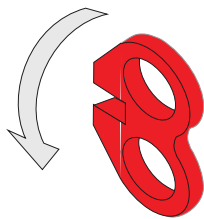

3. Pull the handle away from panel.

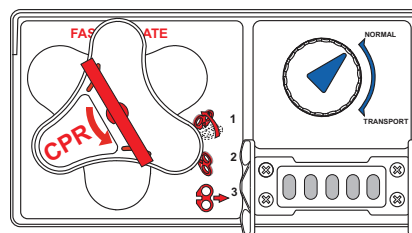
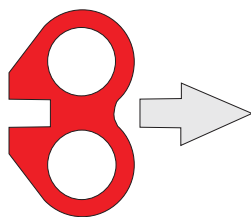

4. The grey triangular seal will rotate and the air will rapidly exhaust from the mattress.

To exit CPR mode

1. Turn the grey triangular seal clockwise and push onto the connectors.
2. Turn the red handle clockwise.
3. Fold the handle flat to lock in position.

6. *Nimbus* Professional Mattress: Patient Positioning Guide

The *Nimbus* Professional mattress allows the patient to be placed in either the Supine (face up) or Prone (face down) positions.

WARNING

A full patient assessment, as to the suitability for Prone Nursing, is essential before commencing the procedure.

Safety sides should be used where appropriate (Refer to “General Safety” on page iii).

It is important that the patient’s head, neck and shoulders are in the correct anatomical position.

When using the Head Section deflate, care must be taken to support the head and neck, and any lines or tubes which are at risk of displacement, and to avoid running lines underneath the head where unrelieved pressure may cause blockage or tissue injury.

Care should be taken at all times to check that all tubes/lines are positioned correctly and do not present a strangulation or trip hazard.

In the Prone position, regular checks should be made to make sure the patient is free from a build up of pressure on the anatomically sensitive areas such as:

- **Head and facial areas including eyes**
- **Top of the shoulders**
- **Sternum**
- **Breasts and genitals**
- **Knees and toes**

General

In both the Supine and Prone positions, patients should be positioned on the mattress so that the shoulders are in line with the Shoulder Support (4th) cell.

NOTE

It is important for the optimal use of the system that patients are positioned correctly on the mattress.

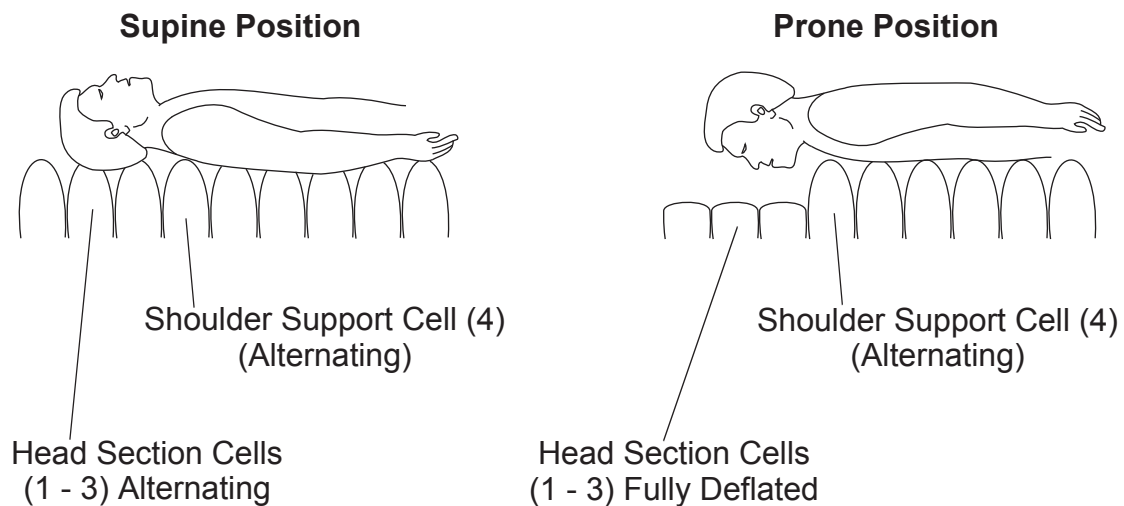

Supine Position (face up)

Make sure the Vent Valves on the three Head Section cells are closed so that the cells are fully inflated to support the head.

In Dynamic mode, all 20 mattress cells, including the Head Section cells, alternate on a 10-minute cycle. This affords protection to all vulnerable areas including the occiput (back of the head).

NOTE

Rarely, some patients prefer not to have gentle cell alternation beneath the head; this can be resolved by placing a thin pillow underneath the head.

Head Section Deflate: Supine Position

- When the patient is in the supine position, the Head Section cells can be deflated to enable:
 - Neck extension (e.g. for emergency procedures or cannulation).
 - Access to the head (e.g. hygiene or wound care).
- The action should be supervised by a competent clinician.
- Always support the neck before and during Vent Valve operation.
- Open the Vent Valves on the three Head Section cells so that up to three of the cells are fully deflated.
- Never leave the patient unattended.
- If the head cells are to remain deflated ensure adequate support of the head and shoulders and provide other methods of routine pressure redistribution.

NOTE

The Shoulder Support (4th) cell will continue to alternate.

Prone Position (face down) - Not for Homecare Environment

- Prone nursing is usually prescribed as an emergency therapy for patients in acute respiratory distress or to manage extensive wounds on the dorsum, such as pressure ulcers or burns.
- The decision to adopt the prone position must be authorised by the clinician responsible for the patient's care.

NOTE

Turning a patient into a prone position carries a moving and handling risk to both the patient and the clinical staff: conduct a full assessment, comply with local protocols and use positioning aids and side rails where necessary.

NOTE

The anaesthetist or most senior member of the team should be positioned at the head end of the bed and will co-ordinate the turning procedure. This person will also be responsible for the safety of the patient's head, neck and ventilation tubing. The other members of the team will help safeguard all lines and assist with the turning procedure as directed.

NOTE

Before commencing the turn, it is recommended that all non-essential lines and monitoring equipment are disconnected.

1. Press the Static button to put the pump into Static mode, so that the mattress cells remain constant with all cells equally inflated.

NOTE

The mattress must be stable and not alternating while the patient is turned, so that the patient is correctly positioned on the mattress.

2. Position the patient so that the shoulders are in line with the Shoulder Support (4th) cell.
3. Open the Vent Valves on the three Head Section cells so that they are deflated.
4. Turn the patient into the prone position whilst supporting the head.
5. Adjust the head position using pillows, foam or gel pads so that a comfortable posture is achieved without hyperextension.
6. Make sure that any lines/tubes are not placed underneath the head, check that the ears are free from pressure and bony prominences are well padded.
7. Check that the shoulders are still in line with the Shoulder Support (4th) cell.

NOTE

The Shoulder Support (4th) cell has no Vent Valve and continues to alternate to provide both support to the patient's shoulders and pressure redistribution over the vulnerable shoulder area.

8. Press the Static button to put the pump back into Alternating mode.

NOTE

Wait for at least one full cycle (10 minutes) before making a final adjustment of any supporting pillows or pads.

9. Determine an individualised repositioning schedule based upon the patient's condition.

7. Decontamination

The following processes are recommended, but should be adapted to comply with the local or national guidelines (Decontamination of Medical Devices) which may apply within the Healthcare Facility or the country of use. If you are uncertain, you should seek advice from your local Infection Control Specialist.

The *Nimbus 4* and *Nimbus Professional* system should be routinely decontaminated between patients and at regular intervals while in use; as is good practice for all reusable medical devices.

WARNING

Remove the electrical supply to the pump by disconnecting the mains power cable from the mains power supply before cleaning.
Protective clothing should always be worn when carrying out decontamination procedures.

Caution

Do not use Phenol-based solutions or abrasive compounds or pads during the decontamination process as these will damage the surface coating. Do not boil or autoclave the cover.
Avoid immersing electrical parts in water during the cleaning process. Do not spray cleaning solutions directly onto the pump.

To clean Clean all exposed surfaces and remove any organic debris by wiping with a cloth moistened with a simple (neutral) detergent and water. Dry thoroughly.

Do not allow water or cleaning solutions to collect on the surface of the pump.

Chemical Disinfection To protect the integrity of the cover we recommend a chlorine-releasing agent, such as sodium hypochlorite, at a strength of 1,000ppm available chlorine (this may vary from 250ppm to 10,000ppm depending on local policy and contamination status).

Wipe all cleaned surfaces with the solution, then wipe with a cloth moistened in water and dry thoroughly.

Alcohol based disinfectants (strength 70%) may be used as an alternative.

Ensure the product is dry before storage.

If an alternative disinfectant is selected from the wide variety available, we recommend that suitability for use is confirmed with the chemical supplier prior to use.

DO NOT WRING/MANGLE, AUTOCLAVE OR USE PHENOLIC BASED SOLUTIONS.

Thermal Disinfection For information for the mattress top cover, including laundering guidelines, refer to “COVER SPECIFICATION” on page 29.

Re-use with multiple patients Professional hygiene maintenance is required before re-use of the system with a different patient.

8. Routine Maintenance

Nimbus 4 and Nimbus Professional Systems

Maintenance The equipment has been designed to be virtually maintenance-free between service periods.

Servicing Arjo will make available on request service manuals, component parts lists and other information necessary for Arjo trained personnel to repair the system.

Service Period Arjo recommend that the *Nimbus 4* and *Nimbus Professional* systems should be serviced after 12 months continuous running time, by an Arjo authorised service agent. This is indicated by the illumination of the Service symbol (refer to “Service Indicator” on page 12).

Nimbus Pump

General Care, Maintenance and Inspection Check all electrical connections and the mains power cable for signs of wear or damage.
Test the Power Fail Alarm before use (refer to “Testing the Power Fail Alarm” on page 8).
If the pump has been subjected to abnormal treatment, e.g. immersed in water or dropped, the unit must be returned to an authorised service centre.

Biofilter The internal biofilter can be run continuously for two years before it requires autoclaving or replacement.
The biofilter can only be replaced by a service engineer.

Nimbus 4 and Nimbus Professional Mattresses

General Care Remove the cover from the mattress.
Inspect the cover for signs of wear or any tears, and check that all cover fasteners are secure.
Check the security of all internal connections, including:

- Between the cells and the manifold.
- To the CPR/Transport Control.

Make sure all cell fasteners are correctly connected to the mattress base sheet and are not loose or damaged.
Make sure the drag handles are fastened to the base cover to remove the risk of tripping.

Serial Number Labels

Pump The serial number label is on the back of the pump case.





Mattress The serial number label is on the top of the CPR/Transport Control.
Quote these serial numbers when requesting service.





9. Troubleshooting and Alarm Conditions

The following table provides a troubleshooting and alarm condition guide for the *Nimbus 4* and *Nimbus Professional* systems in the event of malfunction. These alarms do not cause any delay or interruption in therapy.

NOTE

Refer to Section 4, Page 10 “Controls, Alarms and Indicators” for a comprehensive description of the alarms and indicators on the pump.

Indicator	Possible Cause	Remedy	Priority
No indicators illuminated on the pump control panel.	1. There is no mains power to the pump.	1. Make sure there is a mains power supply to the pump. Make sure the mains power cable is correctly fitted. Call the service engineer.	N/A
 and 	1. The pump is inflating the mattress. 2. CPR control not fully closed.	1. Both indicators extinguish when the operating pressure is reached. 2. Close CPR control.	N/A
	1. The tubeset is not connected properly. 2. The tubeset connectors are damaged. 3. CPR control not fully closed. 4. The Transport control on the mattress is set to Transport. 5. There is a leak in the system	1. Check the tubeset connectors and make sure they are securely connected to the pump and mattress. 2. Make sure the surfaces of the tubeset connectors are clean and not damaged. 3. Close CPR control. 4. Turn the Transport control to Normal. 5. Call the service engineer.	Low priority according to IEC60601-1-8.
	1. The tubeset is blocked.	1. Check that the tubeset is not kinked.	Low priority according to IEC60601-1-8.

 and 	1. Power Fail Alarm. ^(a) The pump has detected a mains power failure.	1. Re-apply mains power or press and hold the Run/ Standby button for 3 seconds to put the pump into Standby. If power failure is prolonged, switch to Transport mode and disconnect the tubeset. The mattress will remain inflated for up to 12 hours. If mains power is re-applied and pump is still not operating, call the service engineer.	Low priority according to IEC60601-1-8.
 and 	1. Pump failure.	1. Do not use the pump. Call the service engineer.	Low priority according to IEC60601-1-8.
	1. The pump needs a service. ^(b)	1. Call the service engineer.	
Mattress cells will not inflate.	1. Vent Valves are open. 2. CPR control not fully closed.	1. Close Vent Valves. 2. Close CPR control.	













- a. If the pump has not been used for a long period, the internal battery which provides the Power Fail Alarm indication may be discharged. Run the pump for a few hours to recharge the internal battery, and the Power Fail Alarm indication will be provided as normal.
To check that the Power Fail Alarm is operating correctly, refer to “Testing the Power Fail Alarm” on page 8.
- b. The service period is set to 12 months run time.

If the trouble shooting procedures do not return the system to normal performance, stop using the system immediately and call the service engineer.









10. Technical Specification

PUMP		
Model:	<i>Nimbus</i>	
Supply Voltage:	220-240 V	100-120 V
Supply Frequency:	50/60 Hz	50/60 Hz
Power Input:	35 VA	
Size:	508 x 220 x 100 mm (20 x 8.7 x 4 in.)	
Weight:	5.7 kg (12.5 lb)	
Case Material:	ABS Plastic	
Plug Fuse Rating:	5A to BS1362 (UK ONLY)	
Pump Fuse Rating:	2 x T1AL 250 V	
Degree of protection against electric shock:	Mains Connected - Class II Type BF.	
Degree of protection against liquid ingress:	IP21 - Protection against ingress of solid objects more than 12.5mm diameter and water droplets falling vertically.	
Mode of operation:	Continuous	

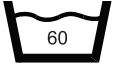
PUMP ENVIRONMENTAL INFORMATION			
Condition	Temperature Range	Relative Humidity	Atmospheric Pressure
Operating	+10°C to +40°C (+50°F to +104°F)	30% to 75% (non-condensing)	700hPa to 1060 hPa
Storage (Long Term)	+10°C to +40°C (+50°F to +104°F)	20% to 95% (non-condensing)	700 hPa to 1060 hPa
Storage (Short Term)	-20°C to +65°C (-4°F to +149°F)	20% to 95% (non-condensing)	500 hPa to 1060 hPa
<p>NOTE</p> <p><i>If the pump is stored in conditions outside the "Operating" ranges, allow time for its temperature to stabilise to normal before use.</i></p> <p>NOTE</p> <p><i>One of the effects of prolonged exposure to high temperatures is to increase the self-discharge of the internal battery; this will reduce the duration of power fail alarms. The pump will fully charge the battery over a 24-hour period when the pump is connected to a mains power supply.</i></p>			

PUMP SYMBOLS					
	The operator must read this document (Instructions for Use) before use. Note: This symbol is blue on the product label.		Type BF		Do not dispose of in domestic refuse
	With respect to electric shock, fire and mechanical hazards only in accordance with CAN/CSA-C22.2 No. 60601.1 (2008)+(2014) and ANSI/AAMI ES60601-1 (2005)+AMD(2012). MEDICAL EQUIPMENT		Serial Number		Model number
	Refer to this document (Instructions for Use) for a description of the product classification (3rd Edition).		Double Insulated		Manufacturer: This symbol is accompanied by the name and the address of the manufacturer.
	Refer to this document (Instructions for Use) for a description of the product classification (2nd Edition).		CE marking indicating conformity with European Community harmonised legislation. Figures indicate Notified Body supervision.		Indicates the product is a Medical Device according to EU Medical Device Regulation 2017/745

TUBE SETS		
Part Number:	151200	151201
Length:	1000 mm (39.4")	2500 mm (98.4")
Materials:	Tube: 5-way moulded PVC Connectors: Moulded Nylon	

MATTRESS CLEANING SYMBOLS			
	Recommended wash temperature: 15 min at 60°C (140°F) Maximum wash temperature: 15 min at 95°C (203°F)		Tumble dry at 60°C (140°F) Maximum drying temperature: 80°C (176°F)
	Recommended wash temperature: 15 min at 60°C (140°F)		Tumble dry at 60°C (140°F)
	Do not iron		Do Not Use Phenol-based cleaning Solutions
	Wipe surfaces with cleaning solution, then wipe with a cloth moistened with water and dry thoroughly		Use solution diluted to 1000 ppm of Available Chlorine

MATTRESS SPECIFICATION		
<i>Nimbus 4</i>	Standard Width	Narrow Width
Reliant IS ² Standard Cover	650001DAR	650201DAR
Premium Fabric Cover	650001P	650201P
Length	2085 mm (82")	
Height:	215 mm (8 1/2")	
Width:	890 mm (35")	800 mm (31 1/2")
Weight:	11.5 kg (25.3 lb)	10.3 kg (22.7 lb)
Cell Material:	Polyurethane	
Base Material:	PU Coated Polyester	
Top Cover Material:	PU Coated Fabric or Premium Fabric	
<i>Nimbus Professional</i>	Standard Width	Narrow Width
Reliant IS ² Standard Cover	651001DAR	651201DAR
Premium Fabric Cover	651001P	651201P
Length	2085 mm (82")	
Height:	215 mm (8 1/2")	
Width:	890 mm (35")	800 mm (31 1/2")
Weight:	15.5 kg (34.1 lb)	14.3 kg (31.5 lb)
Cell Material:	Polyurethane	
Base Material:	PU Coated Polyester	
Top Cover Material:	PU Coated Fabric or Premium Fabric	

PRODUCT				
Mattress SKU	Product Description	Sewn Cover Part Number	Welded Cover Part Number	Premium Cover Part Number
651001DAR	Nimbus Pro	651082	-	-
651201DAR	Nimbus ProNAR	651282	-	-
650001DAR	Nimbus 4	650082	-	-
650201DAR	Nimbus 4 NAR	650282	-	-
651001DARW	Nimbus Pro Welded	-	651082W	-
651201DARW	Nimbus Pro NAR Welded	-	651282W	-
650001DARW	Nimbus 4 Welded	-	650082W	-
650201DARW	Nimbus 4 NAR Welded	-	650282W	-
651001P	Nimbus Pro Premium	-	-	651082P
651201P	Nimbus Pro Narrow Premium	-	-	651282P
650001P	Nimbus 4 Premium	-	-	650082P
650201P	Nimbus 4 NAR Premium	-	-	650282P

COVER SPECIFICATION		
Feature	Standard Cover (Reliant IS²)	Premium Fabric
Removable Cover	Yes	Yes
Moisture Vapour Permeable	Low	Low
Low Friction	No	No
Water Resistant / Repellent	Yes	Yes
Polyurethane coating includes an antimicrobial agent to control microbial deterioration of fabric	Yes	Yes
Fire Retardant^(a)	BS 7175: 0,1 & 5	BS 7175: 0,1 & 5
2-Way Stretch	Yes	Yes
Recommended Wash Temperatures	60°C (140°F) 15 min	60°C (140°F) 15 min
Maximum Wash Temperatures	Max 95°C (203°F) 15 min.	Max 95°C (203°F) 15 min.
Recommended Drying Temperatures	60°C (140°F) or air dry	60°C (140°F) or air dry
Max Drying Temperatures	Max 80°C (176°F)	Max 80°C (176°F)
Wipedown Chemicals^(b)	Chlorine at strength of 1000ppm or Alcohol at 70% concentration; no phenol; ensure product is dry before storage	Chlorine at strength of 1000ppm or Alcohol at 70% concentration; no phenol; ensure product is dry before storage

a. For additional flammability testing standards, refer to individual product law tags, if applicable

b. Chlorine concentrations may vary from 250ppm to 10,000ppm depending on local policy and contamination status. If an alternative disinfectant is selected from the wide variety available, Arjo recommend that suitability for use is confirmed with the chemical supplier prior to use.

11. Electromagnetic Compatibility (EMC)

Product has been tested for compliance with current regulatory standards regarding its capacity to block EMI (electromagnetic interference) from external sources.

Some procedures can help reduce electromagnetic interferences:

- Use only Arjo cables and spare parts to avoid increased emissions or decreased immunity which can compromise the correct functioning of the equipment.
- Ensure that other devices in patient-monitoring and/or life-support areas comply to accepted emissions standards.

WARNING

Wireless communications equipment such as wireless computer network devices, mobile phones, cordless telephones and their base stations, walkie-talkies, etc. can affect this equipment and should be kept at least 1.5m away from the equipment.

Intended Environment: Home Healthcare Environment and Professional Healthcare facility environment.

Exceptions: HF Surgical Equipment and the RF Shielded room of an ME SYSTEM for magnetic resonance imaging

WARNING

Use of this equipment adjacent to or stacked with other equipment should be avoided because it could result in improper operation. If such use is necessary, this equipment and the other equipment should be observed to verify that they are operating normally.

Guidance and manufacturer's declaration - electromagnetic emissions		
Emissions Test	Compliance	Guidance
RF emissions CISPR 11	Group 1	This equipment uses RF energy only for its internal functions. Therefore its RF emissions are very low and are not likely to cause any interference in nearby electronic equipment.
RF emissions CISPR 11	Class B	
Harmonic emissions	Class A	
IEC 61000-3-2		This equipment is suitable for use in all establishments, including domestic establishments and those directly connected to the public low voltage power supply network that supplies buildings used for domestic purposes.
Voltage fluctuations/flicker emissions	Complies	
IEC 61000-3-3		

Guidance and manufacturer's declaration - electromagnetic immunity			
Immunity Test	IEC 60601-1-2 test level	Compliance Level	Electromagnetic environment - guidance
Electrostatic discharge (ESD) EN 61000-4-2	±2kV, ±4kV, ±8kV, ±15kV air ±8kV contact	±2kV, ±4kV, ±8kV, ±15kV air ±8kV contact	Floors should be wood, concrete or ceramic tile. If floors are covered with synthetic material the relative humidity level should be at least 30%
Conducted disturbances inducted by RF fields EN 61000-4-6	3V in 0,15 MHz to 80 MHz 6V in ISM and amateur radio bands between 0,15 MHz and 80 MHz 80% AM at 1 kHz	3V in 0,15 MHz to 80 MHz 6V in ISM and amateur radio bands between 0,15 MHz and 80 MHz 80% AM at 1 kHz	Portable and mobile RF communications equipment should be used no closer to any part of the product, including cables, than 1.0 m, if the transmitter's output power rating exceeds 1W ^(a) Field strengths from fixed RF transmitters, as determined by an electromagnetic site survey, should be less than the compliance level in each frequency range ^(b)
Radiated RF electromagnetic field EN 61000-4-3	Home Healthcare environment 10 V/m 80 MHz to 2,7 GHz 80% AM at 1 kHz	Home Healthcare environment 10 V/m 80 MHz to 2,7 GHz 80% AM at 1 kHz	Interference may occur in the vicinity of equipment marked with this symbol: 
Electrical fast transient/burst EN 61000-4-4	±1kV SIP/SOP ports ±2kV AC port 100kHz repetition frequency	±1kV SIP/SOP ports ±2kV AC port 100kHz repetition frequency	Mains power supply should be that of a typical commercial or hospital environment.
Power frequency Magnetic field EN 61000-4-8	30A/m	30A/m	Power frequency magnetic fields should be at levels characteristic of a typical location in a typical commercial or hospital environment.
Surge IEC 61000-4-5	±0,5kV ±1kV; ±2kV, AC Mains, Line to Ground ±0,5kV ±1kV, AC Mains, Line to Line	±0,5kV ±1kV; ±2kV, AC Mains, Line to Ground ±0,5kV ±1kV, AC Mains, Line to Line	Mains power quality should be that of a typical commercial or hospital environment.

Guidance and manufacturer's declaration - electromagnetic immunity

Voltage dips, short interruptions and voltage variations on power supply input lines	0 % UT; 0,5 cycle At 0°, 45°, 90°, 135°, 180°, 225°, 270° and 315°	0 % UT; 0,5 cycle At 0°, 45°, 90°, 135°, 180°, 225°, 270° and 315°	Mains power quality should be that of a typical commercial or hospital environment. If the user of the pump requires continued operation during power mains interruptions, it is recommended that the pump be powered from an uninterruptible power supply or a battery.
IEC 61000-4-11	0 % UT; 1 cycle and 70 % UT; 25/30 cycles Single phase: at 0°	0 % UT; 1 cycle and 70 % UT; 25/30 cycles Single phase: at 0°	
	0 % UT; 250/300 cycle	0 % UT; 250/300 cycle	

NOTE

UT is the AC mains voltage prior to application of the test level.

a) Field strengths from fixed transmitters, such as base stations for radio (cellular/cordless) telephones and land mobile radios, amateur radio, AM and FM radio broadcast and TV broadcast cannot be predicted theoretically with accuracy. To assess the electromagnetic environment due to fixed RF transmitters, an electromagnetic site survey should be considered. If the measured field strength in the location in which the product is used exceeds the applicable RF compliance level above, the product should be observed to verify normal operation. If abnormal performance is observed, additional measures may be necessary.

b) Over the frequency range 150 kHz to 80 MHz, field strengths should be less than 1 V/m.

AUSTRALIA

Arjo Australia Pty Ltd
78, Forsyth Street
O'Connor
AU-6163 Western Australia
Tel: +61 89337 4111
Free: +1 800 072 040
Fax: + 61 89337 9077

BELGIQUE / BELGIË

Arjo NV/SA
Evenbroekveld 16
BE-9420 ERPE-MERE
Tél/Tel: +32 (0) 53 60 73 80
Fax: +32 (0) 53 60 73 81
E-mail: info.belgium@arjo.be

BRASIL

Arjo Brasil Equipamentos Médicos Ltda
Rua Marina Ciufuli Zanfelice, 329 PB02 Galpão
- Lapa
São Paulo – SP – Brasil
CEP: 05040-000
Phone: 55-11-3588-5088
E-mail: vendas.latam@arjo.com
E-mail: servicios.latam@arjo.com

CANADA

Arjo Canada Inc.
90 Matheson Boulevard West
Suite 300
CA-MISSISSAUGA, ON, L5R 3R3
Tel/Tél: +1 905 238 7880
Free: +1 800 665 4831 Institutional
Free: +1 800 868 0441 Home Care
Fax: +1 905 238 7881
E-mail: info.canada@arjo.com

ČESKÁ REPUBLIKA

Arjo Czech Republic s.r.o.
Na Strži 1702/65
140 00 Praha
Czech Republic
Phone No: +420225092307
e-mail: info.cz@arjo.com

DANMARK

Arjo A/S
Vassingerødvej 52
DK-3540 LYNGE
Tel: +45 49 13 84 86
Fax: +45 49 13 84 87
E-mail:
dk_kundeservice@arjo.com

DEUTSCHLAND

Arjo GmbH
Peter-Sander-Strasse 10
DE-55252 MAINZ-KASTEL
Tel: +49 (0) 6134 186 0
Fax: +49 (0) 6134 186 160
E-mail: info-de@arjo.com

ESPAÑA

Arjo Ibérica S.L.
Parque Empresarial Rivas Futura, C/Marie
Curie 5
Edificio Alfa Planta 6 oficina 6.1-.62
ES-28521 Rivas Vacia, MADRID
Tel: +34 93 583 11 20
Fax: +34 93 583 11 22
E-mail: info.es@arjo.com

FRANCE

Arjo SAS
2 Avenue Alcide de Gasperi
CS 70133
FR-59436 RONCQ CEDEX
Tél: +33 (0) 3 20 28 13 13
Fax: +33 (0) 3 20 28 13 14
E-mail: info.france@arjo.com

HONG KONG

Arjo Hong Kong Limited
Room 411-414, 4/F, Manhattan Centre,
8 Kwai Cheong Road, Kwai Chung, N.T.,
HONG KONG
Tel: +852 2960 7600
Fax: +852 2960 1711

ITALIA

Arjo Italia S.p.A.
Via Giacomo Peroni 400-402
IT-00131 ROMA
Tel: +39 (0) 6 87426211
Fax: +39 (0) 6 87426222
E-mail: Italy.promo@arjo.com

MIDDLE EAST

Arjo Middle East FZ-LLC
Office 908, 9th Floor,
HQ Building, North Tower,
Dubai Science Park,
Al Barsha South
P.O Box 11488, Dubai,
United Arab Emirates
Direct +971 487 48053
Fax +971 487 48072
Email: Info.ME@arjo.com

NEDERLAND

Arjo BV
Biezenwei 21
4004 MB TIEL
Postbus 6116
4000 HC TIEL
Tel: +31 (0) 344 64 08 00
Fax: +31 (0) 344 64 08 85
E-mail: info.nl@arjo.com

NEW ZEALAND

Arjo Ltd
34 Vestey Drive
Mount Wellington
NZ-AUCKLAND 1060
Tel: +64 (0) 9 573 5344
Free Call: 0800 000 151
Fax: +64 (0) 9 573 5384
E-mail: nz.info@Arjo.com

NORGE

Arjo Norway AS
Olaf Helsets vei 5
N-0694 OSLO
Tel: +47 22 08 00 50
Faks: +47 22 08 00 51
E-mail: no.kundeservice@arjo.com

ÖSTERREICH

Arjo GmbH
Lemböckgasse 49 / Stiege A / 4.OG
A-1230 Wien
Tel: +43 1 8 66 56
Fax: +43 1 866 56 7000

POLSKA

Arjo Polska Sp. z o.o.
ul. Ks Piotra Wawrzyniaka 2
PL-62-052 KOMORNIKI (Poznań)
Tel: +48 61 662 15 50
Fax: +48 61 662 15 90
E-mail: arjo@arjo.com

PORTUGAL

Arjo em Portugal
MAQUET Portugal, Lda.
(Distributor Exclusivo)
Rua Poeta Bocage n.º 2 - 2G
PT-1600-233 Lisboa
Tel: +351 214 189 815
Fax: +351 214 177 413
E-mail: Portugal@arjo.com

SUISSE / SCHWEIZ

Arjo AG
Fabrikstrasse 8
Postfach
CH-4614 HÄGENDORF
Tél/Tel: +41 (0) 61 337 97 77
Fax: +41 (0) 61 311 97 42

SUOMI

Arjo Scandinavia AB
Riihitontuntie 7 C
02200 Espoo
Finland
Puh: +358 9 6824 1260
E-mail: Asiakaspalvelu.finland@arjo.com

SVERIGE

Arjo International HQ
Hans Michelsensgatan 10
SE-211 20 MALMÖ
Tel: +46 (0) 10 494 7760
Fax: +46 (0) 10 494 7761
E-mail: kundservice@arjo.com

UNITED KINGDOM

Arjo UK and Ireland
Houghton Hall Park
Houghton Regis
UK-DUNSTABLE LU5 5XF
Tel: +44 (0) 1582 745 700
Fax: +44 (0) 1582 745 745
E-mail: sales.admin@arjo.com

USA

Arjo Inc.
2349 W Lake Street Suite 250
US-Addison, IL 60101
Tel: +1 630 307 2756
Free: +1 800 323 1245 Institutional
Free: +1 800 868 0441 Home Care
Fax: +1 630 307 6195
E-mail: us.info@arjo.com

JAPAN

Arjo Japan K.K.
東京都港区虎ノ門三丁目7番8号 ランディイ
ク第2虎ノ門ビル9階
電話 : +81 (0)3-6435-6401

At Arjo, we are committed to improving the everyday lives of people affected by reduced mobility and age-related health challenges. With products and solutions that ensure ergonomic patient handling, personal hygiene, disinfection, diagnostics, and the effective prevention of pressure ulcers and venous thromboembolism, we help professionals across care environments to continually raise the standard of safe and dignified care. Everything we do, we do with people in mind.



ArjoHuntleigh AB
Hans Michelsensgatan 10
211 20 Malmö, Sweden
www.arjo.com

arjo



649933EN

CE
2797