

Nimbus[®] 3 and Nimbus[®] 3 Professional



User Manual

Contents

Introduction	1
About this Manual	1
About Nimbus 3 and Nimbus 3 Professional	1
Nimbus 3 Pump	2
Nimbus 3 Mattress	3
Nimbus 3 Professional Mattress	4
Clinical Applications	6
Indications	6
Contra-Indications	6
Patient In Chair	6
Installation	7
Preparing the Nimbus 3 and Nimbus 3 Professional Systems for Use	7
Installing the Nimbus 3 or Nimbus 3 Professional Mattress	7
Installing the Pump	9
Connecting the Tubeset	10
Disconnecting the Tubeset	10
System Operation	10
Controls, Alarms and Indicators	11
Pump Controls	11
Pump Indicators	12
Mattress Controls	13
Additional Controls on the Nimbus 3 Professional Mattress	14
Operation	15
Installing the System	15
Inflating the Mattress	15
Testing the Power Fail Alarm	15
Deflating the Mattress	16
System Optimisation	17
Selecting the Operating Mode	17
Silencing Audible Alarms	18
Comfort Control	18
Transport Control	18
CPR Control	19
Patient Positioning Guidance for the Nimbus 3 Professional Mattress	20
Decontamination	22
During Use	22
To Clean	22
To Disinfect	22
To Launder the Mattress Top Cover	23
Routine Maintenance	24
Nimbus 3 and Nimbus 3 Professional Systems	24

Nimbus 3 Pump	24
Nimbus 3 and Nimbus 3 Professional Mattresses	24
Serial Number Labels	25
Troubleshooting	26
Fuse Replacement	27
Warranty and Service	28
Technical Description	29
Cover Options and Features	32

General Safety

Before you connect the system pump to a mains socket, read carefully all the installation instructions in Section 3, Page 7 “Installation”. The system has been designed to comply with regulatory safety standards including:

EN60601-1:1990/A13:1996.

Safety Warnings

- The cover of this product is vapour permeable but not air permeable and may present a suffocation risk. It is the responsibility of the care giver to ensure that the user can use this product safely.
- Electrical equipment may be hazardous if misused. The pump's rear case should only be removed by authorised technical personnel.
- Do not use the pump in the presence of flammable gases such as anaesthetic agents.
- Whilst the patient is unattended, safety sides should be used based on clinical assessment and in line with local hospital policy.
- Alignment of the bed frame, safety sides and the system should leave no gap wide enough to entrap a patient's head or body. Care should be exercised to prevent occurrence of gaps by compression or movement of the mattress. Death or serious injury may occur.
- Due to the inherently lower flame retardancy of the high performance eVENT[®] a fabric, it is **NOT** suitable for use in the homecare environment.

a. eVENT[®] is a registered trademark of BHA Technologies Inc.

Precautions

For your own safety and the safety of the equipment, always take the following precautions:

- Placing extra layers between the patient and the mattress potentially reduces the benefits provided by the mattress and should be avoided or kept to a minimum. As part of sensible pressure area care, it is advisable to avoid wearing clothing which may cause areas of localised high pressure due to creases, seams, etc. Placing objects in pockets should be avoided for the same reason.
- Keep the pump away from sources of liquids and do not immerse in water.
- Do not expose the system, especially the mattress, to naked flames, such as cigarettes, etc.
- Do not store the system in direct sunlight.
- Switch off the mains power supply to the pump, by disconnecting the pump from the mains socket, before cleaning and inspecting.
- Do not use phenol-based solutions to clean the system.
- Make sure the system is clean and dry prior to use or storage.
- Never use sharp objects or electrically heated under blankets on or under the system.
- Store the pump and mattress in the protective bags supplied.
- Only the pump and mattress combination as indicated by Huntleigh Healthcare should be used. The correct function of the product cannot be guaranteed if incorrect pump and mattress combinations are used.

1. Introduction

About this Manual

This manual is your introduction to the **Nimbus® 3** and **Nimbus 3 Professional** systems. Use it to initially set up the system, and keep it as a reference for day-to-day routines and as a guide to maintenance.

About Nimbus 3 and Nimbus 3 Professional

Nimbus 3 and Nimbus 3 Professional are Dynamic Flotation Systems for the prevention, treatment and management of pressure ulcers.

Nimbus 3 and Nimbus 3 Professional systems comprise a pump and mattress replacement which can be used on standard hospital and normal domestic beds. Beds can be adjusted or profiled with the mattress in position.

The **Nimbus 3 Professional** mattress has the following additional features to enable the patient to be prone, and to assist with pressure area and patient care management:

- A Head Section Deflate Control to allow the three head cells to be fully deflated.
- Individual Vent Valves to allow 16 of the 20 cells to be independently deflated.

The **Nimbus 3 and Nimbus 3 Professional** mattresses incorporate an advanced **AutoMatt®** sensor pad which makes sure that the patient is automatically supported at optimum pressures regardless of size, height, position or weight distribution.

If cardiac arrest occurs, the **Nimbus 3 and Nimbus 3 Professional** mattresses can be deflated in less than 10 seconds to allow cardiac resuscitation procedures to be performed.

Nimbus 3 Pump The same pump is used on the **Nimbus 3** and **Nimbus 3 Professional** systems.

The pump comprises a moulded case with non-slip feet on the base and rear, and an integral carry handle.

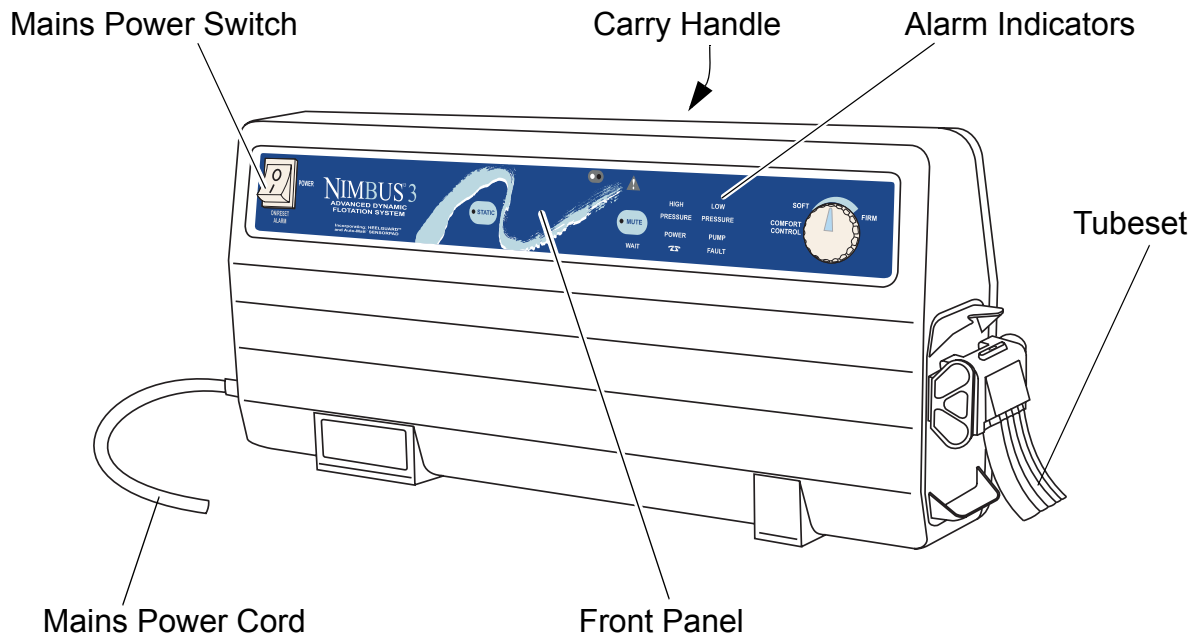

The pump has two modes of operation:

- **Dynamic** mode that cycles the support surface beneath the patient every 10 minutes providing periods of pressure relief for the whole body.
- **Static** mode where the support surface remains constant (all cells equally inflated).

The controls and indicators are located on the front panel, and a sophisticated alarm system differentiates between normal operation and genuine system faults. If an alarm situation is detected a flashing indicator will illuminate, together with an indication of the cause of alarm, and an audible warning will sound.

The pump can be fixed to the foot end of a hospital bed by the separate bed bracket. The bed bracket fits in the pump handle and then clips onto most common bed frames. The pump can also be stood on the floor, either upright or on its rear cover.

Nimbus 3 Mattress The **Nimbus 3** mattress comprises the following components:

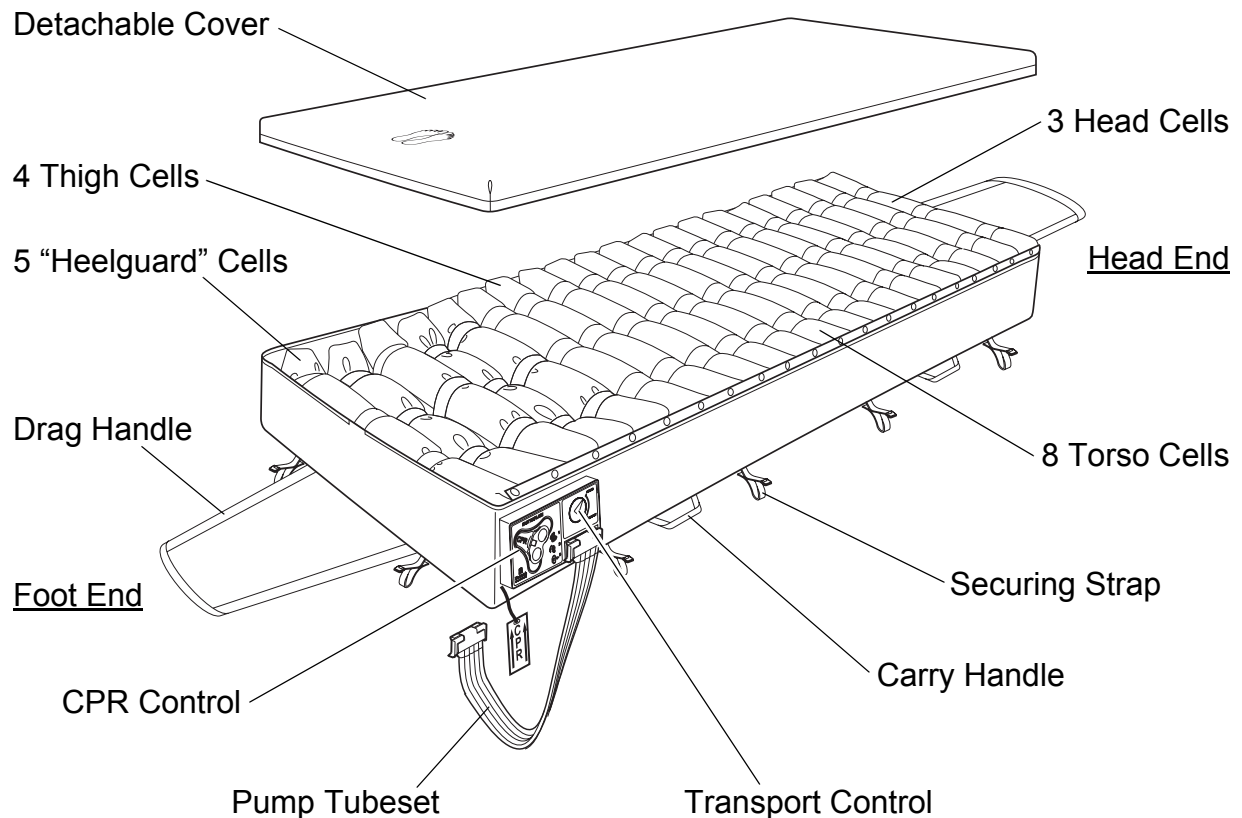

Detachable Cover The standard protective cover comprises a 2-way stretch cover zipped to a durable anti-slip base. The zips are protected by flaps to prevent ingress of contaminants, and allow easy removal of the cover for cleaning. Alternative covers with advanced properties, such as Advantex[®] and eVENT[®], are also available (Refer to “Cover Options and Features” on page 32).

Cells The **Nimbus 3** mattress comprises 20 polyurethane (PU) cells providing support to the user in either Alternating or Static modes. The cells are grouped in four sections, each of which has a specific function:

- The three Head cells remain at a constant pressure for pillow stability and patient comfort.
- The eight Torso cells combine alternating and static pressure characteristics to support patients fully in both lying and sitting positions without the risk of ‘bottoming’.
- The four Thigh cells cycle dynamically to maximise pressure relief.
- The five **Heelguard**[®] cells are specially powered to maximise the pressure relief under the heels.

AutoMatt The advanced **AutoMatt** sensor pad is under the cells, and makes sure that the patient is automatically supported at optimum pressures regardless of size, height, position or weight distribution.

CPR Control The CPR (Cardio-Pulmonary Resuscitation) Control is at the foot end of the mattress, and allows the air to be evacuated in under 10 seconds.

Transport Control The Transport Control is next to the CPR Control. When operated, it seals the mattress so that air is not exhausted when the tubeset is disconnected and also creates an even pressure in all the cells.

Tubeset The tubeset incorporates a flexible, compact anti-kink tube that is resistant to crushing and any subsequent obstruction of air flow. Each end has a quick-lock system for easily connecting and disconnecting the air supply at the pump and mattress.

Nimbus 3 Professional Mattress

The **Nimbus 3 Professional** mattress is of similar construction to the **Nimbus 3** mattress, with the addition of a Head Section Deflate Control, individual Vent Valves on 16 of the 20 cells and a Shoulder Support Cell.

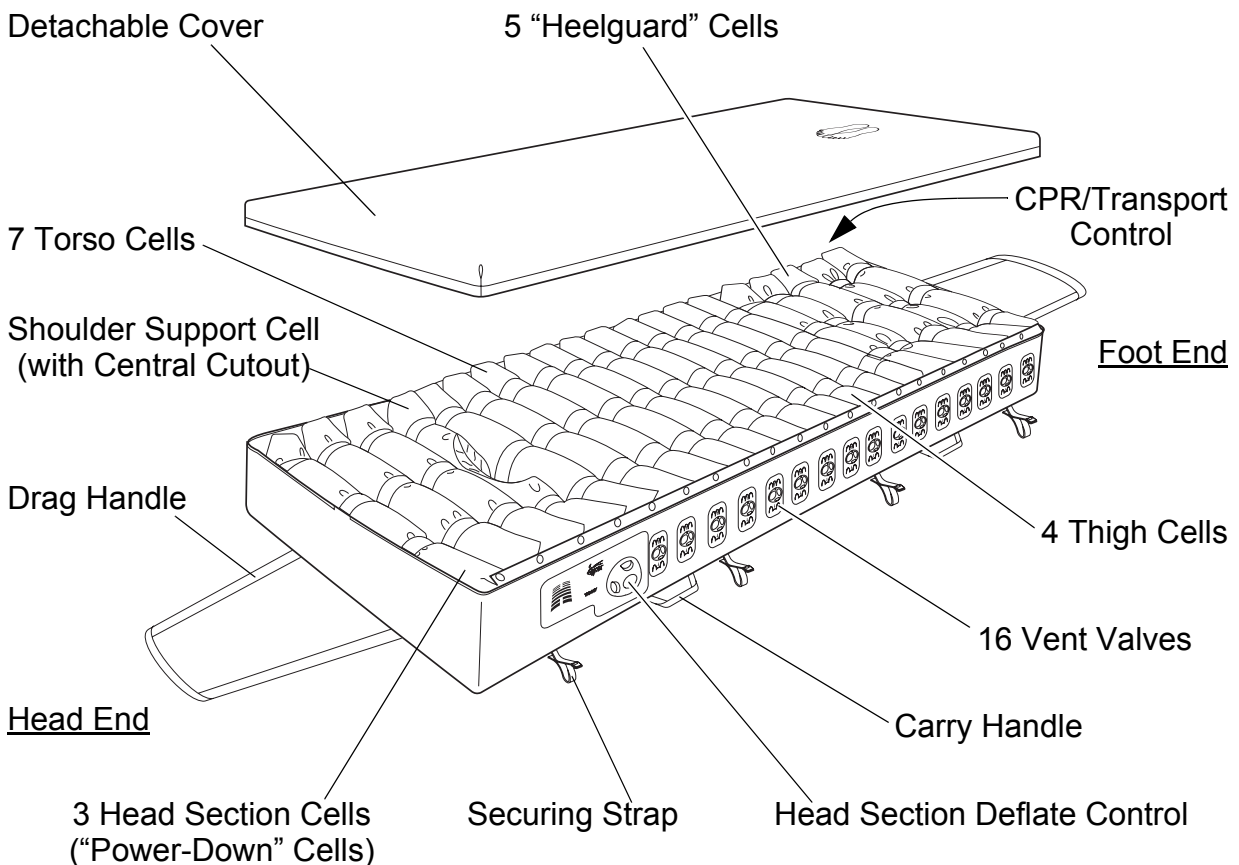

Head Section Deflate Control

This is a two-position rotary-action control at the head end of the mattress:

- **Dynamic (Normal) Mode.** The three cells in the Head Section are inflated at a constant pressure and the remaining 17 cells alternate.
- **TriCell Head Section Deflate.** The three cells in the Head Section are fully deflated to assist with patient care management, and the Shoulder Support Cell (the fourth cell, next to the Head Section) is inflated to a constant pressure to support the patient's shoulders. The remaining 16 cells alternate.

Cells

The **Nimbus 3 Professional** mattress has the same number of cells as the **Nimbus 3** mattress (20 cells). The function of the first four cells at the head end of the mattress is different on the **Nimbus 3 Professional**:

- The three cells in the Head Section are either fully inflated or fully deflated, depending on the position of the Head Deflate Control, to assist with patient care management. The cells are specially powered to enable them to be fully deflated.
- The single Shoulder Support Cell (the fourth cell, next to the Head Section) has a shallow cutout in the mid-section of the cell. This is to allow access to the neck area for clinical procedures and to ensure the smooth, uniform extension of the neck during deflation. Its operation is controlled by the Head Section Deflate Control: the cell is either fully inflated to support the patient's shoulders or alternates (together with the remaining 16 cells).
- The remaining 16 cells (seven Torso cells, four Thigh cells and five **Heelguard** cells) have the same basic function as on the **Nimbus 3** mattress.

Vent Valves

The seven Torso cells, four Thigh cells and five **Heelguard** cells have individual Vent Valves to allow each cell to be independently deflated, to assist with pressure area and patient care management.

2. Clinical Applications

Indications The **Nimbus 3** and **Nimbus 3 Professional** systems are indicated for patients weighing up to 250 kg (39 stones) and are suitable for the prevention and management of all grades of pressure ulcers.

Contra-Indications The **Nimbus 3** and **Nimbus 3 Professional** systems, both in alternating and static modes, should not be used for patients with unstable spinal fractures.

In the case of patients with other unstable fractures, where a moving surface can be harmful, advice should be obtained from the appropriate physician before using the **Nimbus 3** or **Nimbus 3 Professional** systems in both alternating and static modes.

Patient In Chair If the patient will be sitting in a chair for any period of time, it is strongly recommended that a pressure reducing or relieving seat cushion is used.

 *The **Nimbus 3** and **Nimbus 3 Professional** systems are an aid to the prevention and management of pressure ulcers. If there is no improvement in the patient's condition, clinical advice should be sought.*

 *The above are guidelines only and should not replace clinical judgement or experience.*

3. Installation

The **Nimbus 3** and **Nimbus 3 Professional** systems are very simple to install using the following guidelines.

 Refer to Section 4, Page 11 “Controls, Alarms and Indicators” for a comprehensive description of the controls and indicators on the pump and mattress.

Preparing the Nimbus 3 and Nimbus 3 Professional Systems for Use

1. Remove the system from the packaging. You should have the following items:
 - **Nimbus 3** pump, with integral mains power cord.
 - **Nimbus 3** mattress replacement or the **Nimbus 3 Professional** mattress replacement.
 - Bed bracket.
 - Tubeset.

Installing the Nimbus 3 or Nimbus 3 Professional Mattress

1. Remove the conventional mattress from the bed frame and check that there are no protruding bed springs or sharp objects on the bed frame surface.

 *Heavily ridged bed baseboards may require special considerations for correct system operation - consult your Huntleigh Healthcare representative.*

2. Unroll the mattress onto the bed base and make sure that the CPR is at the foot end, and the CPR label is hanging freely.
3. Attach the mattress to the bed frame using the hook and loop securing straps.

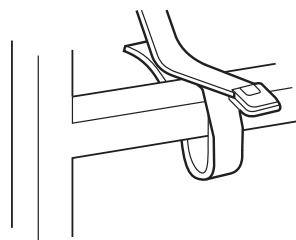

 *If the bed can be profiled to any position (i.e. raised or lowered), attach the mattress to the movable parts of the bed only.*

4. Check the **AutoMatt** sensor pad, as follows:
 - Unzip the cover on one side of the mattress only.
 - Pull the side of the mattress away from the cells.
 - The **AutoMatt** sensor pad is situated under the cells between the soft and hard foam sheets.
 - Make sure that the **AutoMatt** sensor pad is lying flat and is not “kinked”.
 - Zip the cover back onto the mattress, taking care not to trap any cell material in the zip.

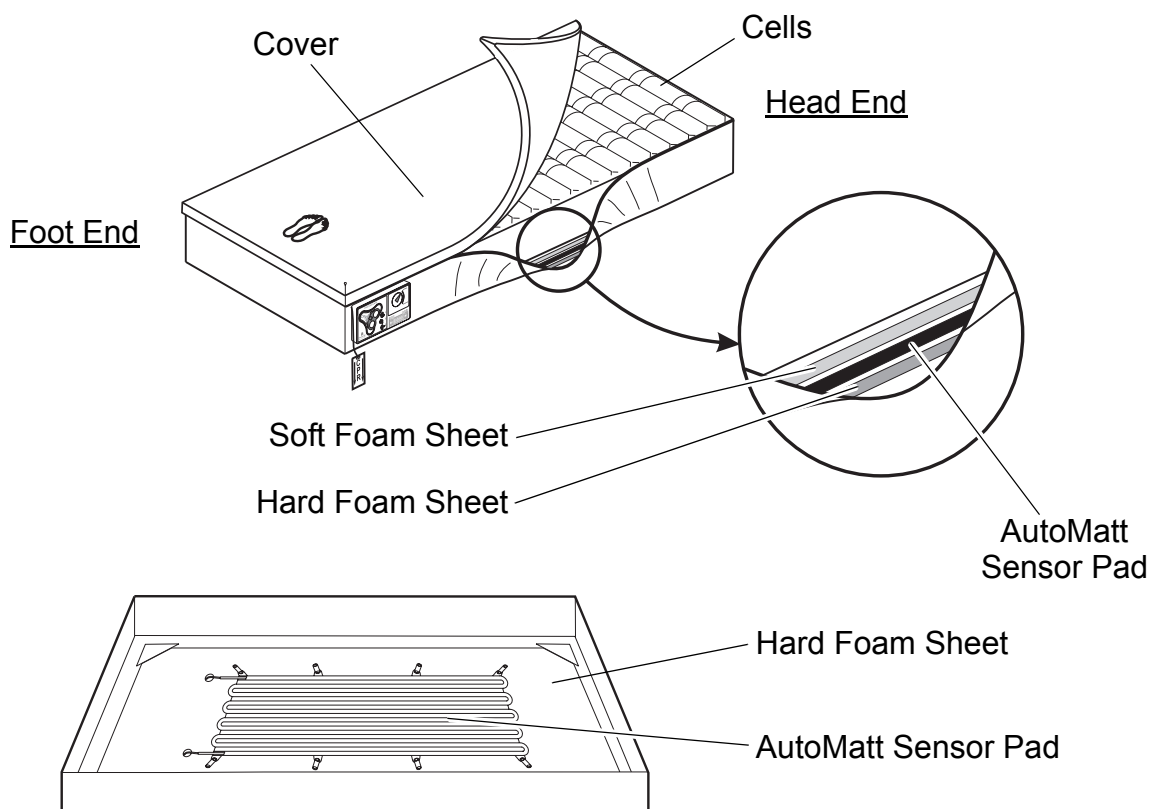

5. Leave the ends of the mattress cover free when profiling the bed.
6. Make sure the CPR control is closed and locked in position and the Transport control is set to **NORMAL**.

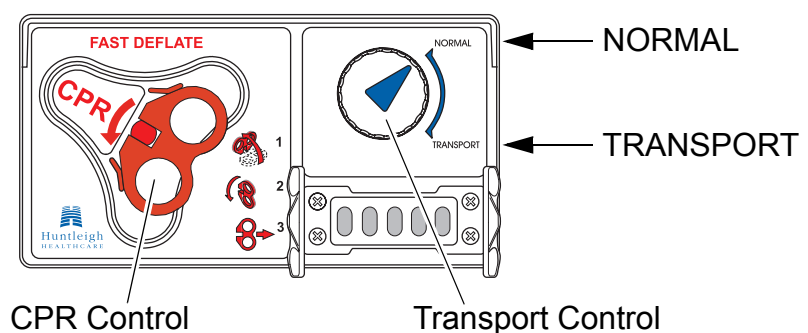

**Additional Checks on
the Nimbus 3
Professional Mattress**

1. Make sure that all 16 Vent Valves are closed.

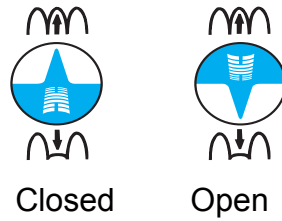

2. Make sure that the Head Section Deflate Control is set to **Dynamic (Normal) Mode**.

TriCell Head Section Deflate

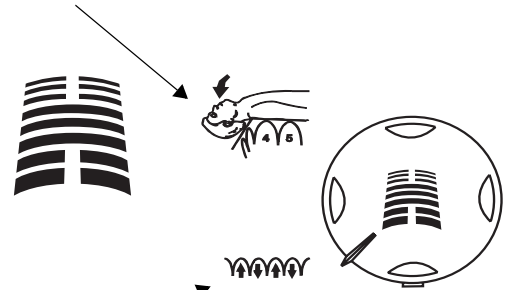

Dynamic (Normal) Mode

Installing the Pump

1. If the pump is to be hung from the end of the bed, make sure that the bed bracket is securely attached to the pump, and then attach the pump and bed bracket to the bed frame.

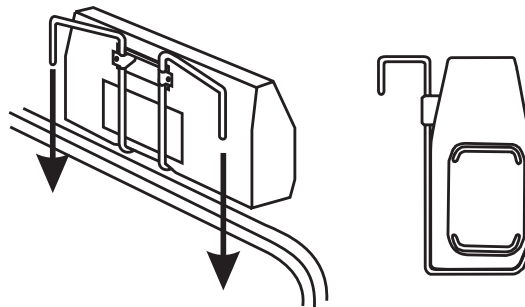

2. Alternatively the pump can be placed underneath the bed, either upright or lying on its back.
3. Insert the connector on the end of the mains power cord into a suitable mains power outlet.

Connecting the Tubeset

To connect the tubeset to the mattress and pump:

1. Locate the bottom of the tubeset connector onto the bottom of the pump/mattress connector.
2. Pull the top of the tubeset connector up and over the top of the pump/mattress connector, until the tubeset connector “clicks” into position.
3. Make sure both connections are secure.

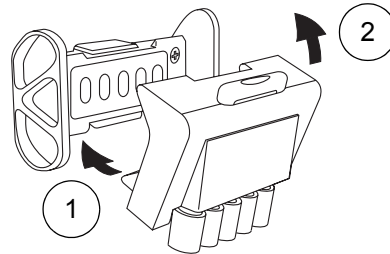

Disconnecting the Tubeset

To disconnect the tubeset from the mattress and pump:

1. Move the tubeset connector down by pulling the tubeset extrusion downwards, and then pull the bottom of the tubeset connector away from the bottom of the pump/mattress connector.
2. Lift the top of the tubeset connector off the top of the pump/mattress connector.

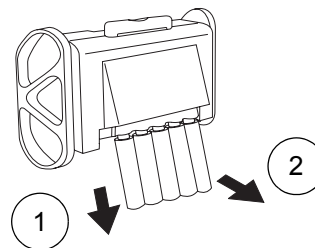

System Operation

The system is now ready for use. Refer to Section 4, Page 11 “Controls, Alarms and Indicators” and Section 5, Page 15 “Operation” for day-to-day operating instructions.

WARNING

Make sure the mains power cord and tubeset are positioned to avoid causing a hazard.

Caution

Make sure the mains power cord and tubeset are clear of moving bed mechanisms or other possible entrapment areas.

4. Controls, Alarms and Indicators

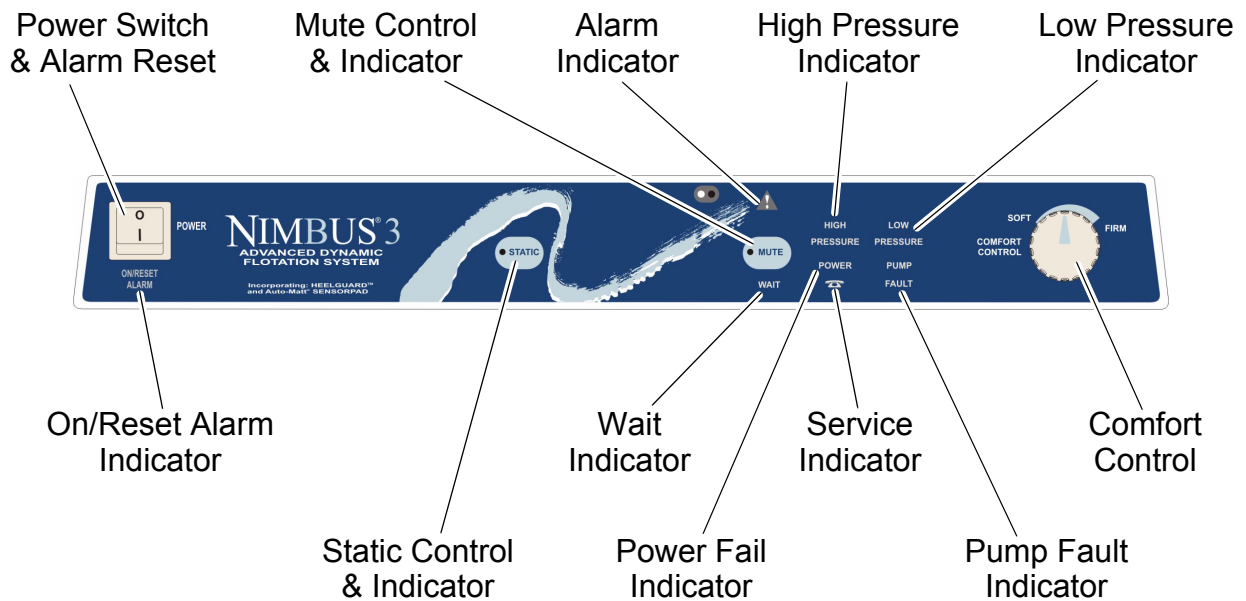

Pump Controls

The pump front panel has the following controls:

POWER Switch (and RESET ALARM)

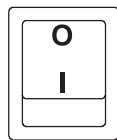

Switches the mains power to the pump on and off.

The green **ON / RESET ALARM** indicator is illuminated when the mains power is connected and the pump switched on.

The switch is also used to reset the pump after an alarm condition has been detected.

STATIC Mode



Selects the operating mode, either **Static** or **Dynamic**.

Static mode is confirmed when the yellow indicator on the button is illuminated.

When **Dynamic** mode (default) is selected the yellow indicator will be extinguished.

Alarm MUTE



An audible alarm mute is provided to cancel warning sounds during an alarm condition.

COMFORT CONTROL

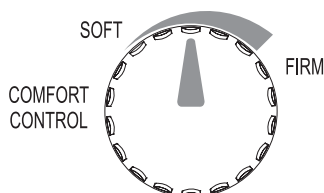

This is a rotary action control to set the relative firmness/softness of the mattress for patient comfort.

Pump Indicators The pump front panel has the following indicators:

ON / RESET ALARM The green **ON / RESET ALARM** indicator below the **POWER** switch is illuminated when the mains power is connected and the pump switched on.

STATIC Mode The indicator on the **STATIC** button is illuminated when **Static** mode has been selected for operation.

Alarm MUTE The indicator on the **MUTE** button is illuminated when an audible alarm has been silenced.



*The indicator will **NOT** be illuminated when a Power Fail alarm is muted.*

WAIT

The **WAIT** indicator is illuminated when the mattress is being inflated.

The indicator will remain illuminated until the mattress has been fully inflated. This may take up to 15 minutes.

HIGH PRESSURE

The **HIGH PRESSURE** indicator is illuminated whenever the pump detects high pressure within the mattress.

If this condition occurs, the air supply from the pump is switched off until normal pressure is detected. After 2 seconds of normal pressure being detected the indicator is switched off and the air supply restarted.

LOW PRESSURE

The **LOW PRESSURE** indicator is illuminated whenever the pump detects low pressure within the mattress.

This may indicate that there is insufficient pressure to support a patient or that the Transport control is turned to the **TRANSPORT** position whilst the pump is on and connected to the mattress.

The **LOW PRESSURE** indicator will be switched off once normal pressure is reached.

Alarm



The pump unit incorporates a sophisticated alarm detection system that differentiates between patient movement and genuine alarm conditions.

Whenever an alarm condition is detected the red **Alarm** triangle starts flashing together with an indicator of the cause of the alarm. Additionally, an audible warning will sound, which can be cancelled by pressing the **Alarm MUTE** button (Refer to “Alarm MUTE” on page 11).

The triangular **Alarm** symbol is displayed with one or more of the following indicators:

- **LOW PRESSURE** (Refer to “LOW PRESSURE” on page 12).
- **HIGH PRESSURE** (Refer to “HIGH PRESSURE” on page 12).
- **PUMP FAULT** (Refer to “PUMP FAULT” on page 13).
- **POWER** (Refer to “POWER Fail” on page 13).



*For all alarm conditions except **Power Fail**, once the alarm condition has been detected and displayed, it can only be cancelled by switching the pump unit off and then back on.*

Refer to Section 8, Page 26 “Troubleshooting” for possible causes of the above alarm conditions.

PUMP FAULT



The **PUMP FAULT** indicator is illuminated when an internal pump malfunction is detected.

The fault can only be rectified by carrying out a service on the pump.

POWER Fail



The **POWER** indicator will flash when a mains power failure has been detected.

The alarm will continue until the mains power is resumed or the pump is switched off using the **POWER** switch on the pump control panel.

Service Indicator



The “telephone” symbol  will be illuminated after a set number of running hours to indicate that the pump is ready for a service.

This service period is set to 12 months.



The pump will continue to operate normally even when the  symbol is illuminated.

Mattress Controls

All **Nimbus 3** and **Nimbus 3 Professional** mattresses have the following two controls, situated at the foot end of the mattress:

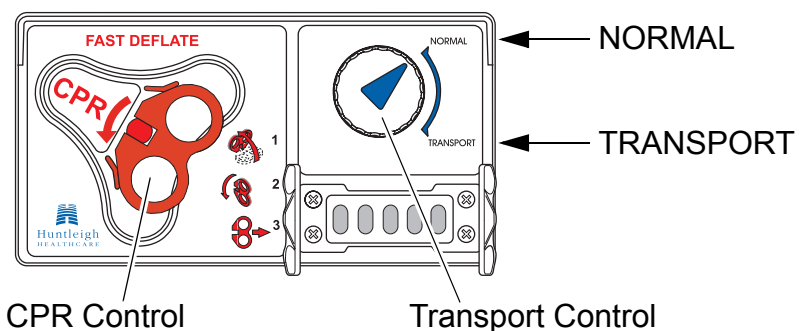

Transport Control This sets the mattress into **TRANSPORT** mode where the support surface is equally pressurised and the pump and tubeset can be removed. In this mode the mattress will support the patient for up to 12 hours.

CPR Control The CPR (Cardio-Pulmonary Resuscitation) Control provides a means of rapidly deflating the mattress to allow normal resuscitation procedures to be carried out.

 *The CPR control is used to deflate the mattress for packing and storage.*

Additional Controls on the Nimbus 3 Professional Mattress

The following two controls are on the opposite side of the mattress to the CPR/Transport Control:

Head Section Deflate Control This is a two-position rotary-action control at the head end of the mattress:

- **Dynamic (Normal) Mode.** The three cells in the Head Section are inflated at a constant pressure and the remaining 17 cells alternate.
- **TriCell Head Section Deflate.** The three cells in the Head Section are fully deflated to assist with patient care management, and the Shoulder Support Cell (next to the Head Section) is inflated to a constant pressure to support the patient's shoulders. The remaining 16 cells alternate.

TriCell Head Section Deflate

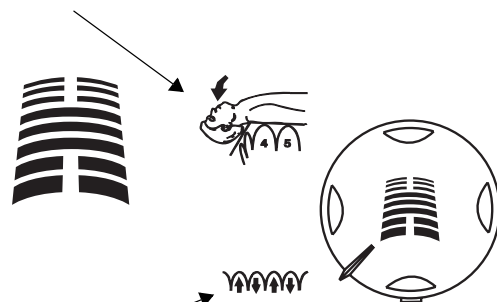

Dynamic (Normal) Mode

16 Vent Valves The seven Torso cells, four Thigh cells and five **Heelguard** cells have individual Vent Valves to allow each cell to be independently deflated, to assist with pressure area and patient care management.

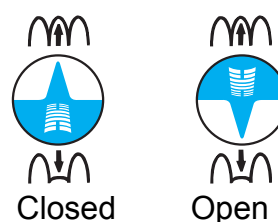

5. Operation

These instructions cover day-to-day operation of the system. Other operations, such as maintenance and repair, should only be carried out by suitably qualified personnel.

 Refer to Section 4, Page 11 “Controls, Alarms and Indicators” for a comprehensive description of the controls and indicators on the pump and mattress.

Installing the System Before using the **Nimbus 3** or **Nimbus 3 Professional** system make sure:

1. The system has been installed correctly in accordance with Section 3, Page 7 “Installation”.
2. The CPR unit on the mattress is closed and locked in position.
3. The Transport control on the mattress is set to **NORMAL**.
4. If a **Nimbus 3 Professional** system is being installed, make sure that on the mattress:
 - All 16 Vent Valves are closed.
 - The Head Section Deflate Control is set to **Dynamic (Normal) Mode**.

Inflating the Mattress

1. Switch the pump **POWER** switch to **ON**. The **ON / RESET ALARM** indicator below the **POWER** switch should illuminate.
2. The pump will now run a self test for approximately 3 seconds when all the indicators on the front panel will be illuminated.
3. If the pump detects low pressure (e.g. a deflated mattress) it will enter an inflation sequence with the **LOW PRESSURE** and **WAIT** indicators illuminated.
4. Once normal operating pressure has been reached both the **LOW PRESSURE** and **WAIT** lights will extinguish.

 It may take up to 15 minutes to inflate the mattress.

The three Head Section cells and the five Heelguard cells will inflate more slowly than the rest of the mattress.

Testing the Power Fail Alarm The Power Fail Alarm is powered by a rechargeable battery. The duration of the alarm will depend on the level of charge in the battery.

The battery may have become discharged or reached the end of its life. It is therefore recommended that the alarm is tested before the pump is used, as follows.

1. Connect the pump to the mains power supply, switch **ON** and allow it to run for 10-15 seconds.
2. Remove the mains power at the wall socket *without* switching the pump off.
3. The power fail alarm should operate within 10 seconds, as follows:
 - The red **Alarm** triangle will flash.
 - The **POWER** indicator will flash.
 - An audible warning will sound.
4. The alarm will continue until the mains power is resumed or the pump is switched off using the **POWER** switch on the pump control panel.
5. If the alarm does not operate, run the pump for approximately four hours to recharge the battery.
6. Retest the alarm after the battery has been recharged. Allow the alarm to operate for approximately two minutes to ensure that it has been adequately recharged.
7. If the alarm does not operate for two minutes, call the service engineer.



If the Power Fail Alarm does not operate after this test and a service engineer has been called, the pump can continue to be used with regular checks of the Power-On status.

All other alarms will continue to function as normal.

Deflating the Mattress

To deflate and store the mattress, do the following:

1. Switch off the pump, and disconnect the pump from the mains power supply.
2. Remove the tubeset from the pump and mattress (Refer to “Disconnecting the Tubeset” on page 10).
3. Activate the CPR control.
4. Make sure the Transport control is set to **NORMAL**.
5. Roll up the mattress, starting at the foot end.



Make sure the mattress is dry before rolling it up.

System Optimisation The **Nimbus 3** and **Nimbus 3 Professional** systems automatically compensate for patient weight distribution and position, to optimise the pressure relieving performance.

 *To make sure that the pressure relieving properties are not impaired, the mattress cover must not be pulled tight and covering sheets should fit loosely using the attached clips.*

The system provides two modes of operation:

- **Dynamic** mode provides the optimum pressure relieving performance and should be used in most cases. In **Dynamic** mode the support surface beneath the patient is cycled every 10 minutes.
- **Static** mode provides a stable, non-moving support surface for instances where a dynamic support surface is contra-indicated. In **Static** mode the support surface remains constant (all cells are equally inflated).

***Nimbus 3 Professional
Mattress only***

On the **Nimbus 3 Professional** system, the following therapeutic positioning controls along the side of the mattress offer further operating modes in combination with the **Dynamic** pressure relief option, to assist with pressure area and patient care management:

1. Head Section Deflate Control. This controls the three cells in the Head Section:
 - **Dynamic (Normal) Mode**, where the three Head cells are inflated at a constant pressure and the remaining 17 cells alternate.
 - **TriCell Head Section Deflate**, where the three Head cells are fully deflated, and the Shoulder Support Cell is inflated to a constant pressure to support the patient's shoulders. The remaining 16 cells alternate.
2. 16 Vent Valves.
The seven Torso cells, four Thigh cells and five **Heelguard** cells have individual Vent Valves to allow each cell to be independently deflated.

**Selecting the
Operating Mode**

- The pump defaults to the **Dynamic** operating mode when switched on.
- Both **Static** and **Dynamic** modes of operation are selected by the **STATIC** button on the front panel.
- When **Static** mode is selected the indicator on the **STATIC** button illuminates.

To change the operating mode:

1. To select **Static** mode from **Dynamic** mode press the **STATIC** button once. An audible tone will sound and the indicator on the button will illuminate to show that the system is in **Static** mode.
2. To select **Dynamic** mode from **Static** mode press the **STATIC** button once. An audible tone will sound and the indicator on the button will extinguish.

Silencing Audible Alarms Audible alarms can be silenced using the **MUTE** button. To silence an alarm push the **MUTE** button once (the indicator on the **MUTE** button will remain illuminated).

 *In its normal operating mode an audible alarm can only be silenced after an alarm has occurred. An internal setting can be used to change the mode of operation so that this button can pre-silence an alarm. Call your service engineer if this option is required.*

Comfort Control The mattress cell pressure can be manually adjusted for patient comfort using the rotary **COMFORT CONTROL**. To change the comfort setting:

- Turn **COMFORT CONTROL** clockwise for a firmer setting and counterclockwise for a softer setting.
- The mattress minimum pressure is maintained at the chosen level.

 *The system automatically compensates for patient size, height, position and weight distribution to provide optimum support regardless of the **COMFORT CONTROL** setting.*

Transport Control This seals the mattress and allows the removal of the pump for patient transport. The patient will remain supported by the mattress for up to 12 hours in **Transport** mode. To set the **Transport** mode:

1. At the foot end of the mattress turn the Transport control knob clockwise to **TRANSPORT**.
2. Turn the pump off and disconnect the tubeset.

 *If the Transport control is set to **TRANSPORT** with the tubeset connected and the pump switched on, then the pump will indicate a **Low Pressure** fault alarm.*

To resume normal operation:

1. Re-connect the pump and tubeset to the mattress.
2. Turn the Transport control knob counterclockwise to **NORMAL**.

CPR Control

IMPORTANT IN THE EVENT OF CARDIAC ARREST.

In the event of a patient suffering cardiac arrest and CPR needing to be administered:

- To Activate the CPR**
1. Lift the red CPR handle at the foot end of the mattress.

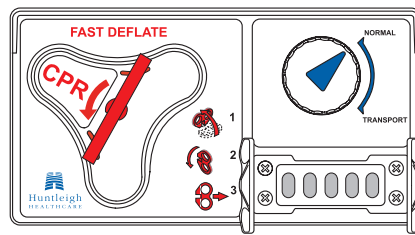
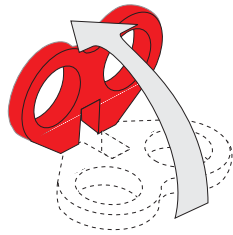

2. Turn the handle counterclockwise.

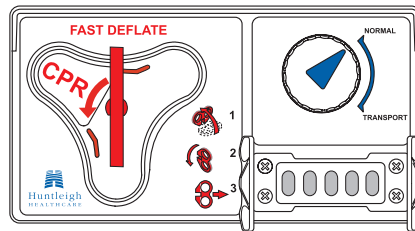
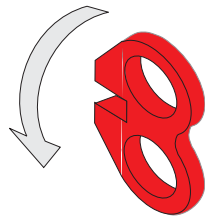

3. Pull the handle away from panel.

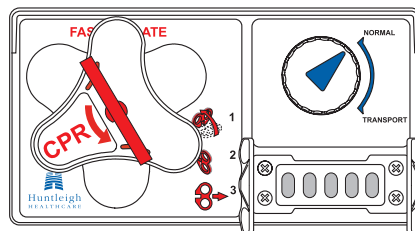
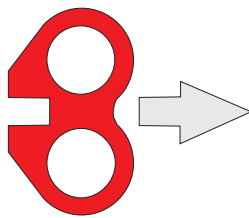

4. The grey triangular seal will rotate and the air will exhaust from the mattress. The torso area of the patient will bottom out in less than 10 seconds.

- To Reset the CPR**
1. Turn the grey triangular seal clockwise and push onto the connectors.
 2. Turn the red handle clockwise.
 3. Fold the handle flat to lock in position.

Patient Positioning Guidance for the Nimbus 3 Professional Mattress

The **Nimbus 3 Professional** mattress allows the patient to be placed in either the Supine or Prone positions.

WARNING

A full patient assessment, as to the suitability for Prone Nursing, is essential before commencing the procedure.

Safety sides should be used where appropriate (Refer to “Safety Warnings” on page iii).

It is important that the patient’s head, neck and shoulders are in the correct anatomical position.

Care should be taken at all times to check that all tubes/lines are positioned correctly.

In the Prone position, regular checks should be made to make sure the patient is free from a build up of pressure on the anatomically sensitive areas such as:

- **Head and facial areas including eyes**
- **Top of the shoulders**
- **Sternum**
- **Breasts and genitals**
- **Knees and toes**

 *It is important for the optimal use of the system that patients are positioned correctly on the mattress.*

1. In both the Supine and Prone positions, patients should be positioned on the mattress so that the tops of their shoulders lie between the third and fourth cells.
2. Supine Position.

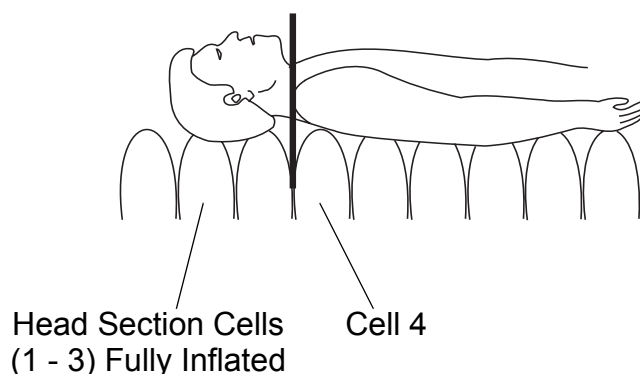

3. Prone Position.

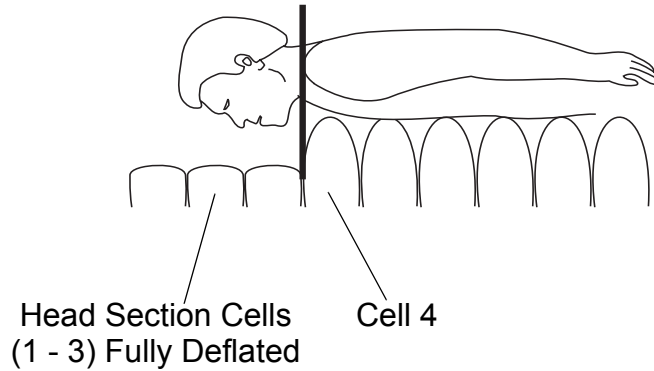

4. It is recommended that a minimum of four staff will be required to turn the patient from the Supine to the Prone position.
 - The anaesthetist or most senior member of the team should be positioned at the head end of the bed and will co-ordinate the turning procedure. This person will also be responsible for the safety of the patient's head, neck and ventilation tubing.
 - The other members of the team will help safeguard all lines, and assist with the turning procedure as directed.



Before commencing the turn, it is recommended that all non-essential lines and monitoring equipment are disconnected.

5. With the patient in the Supine or Prone positions, the mattress controls can be configured as follows:
 - Set the Head Section Deflate Control to **TriCell Head Section Deflate** (where the 3 Head cells are fully deflated, and the Shoulder Support Cell is fully inflated to support the patient's shoulders) which can assist with intubation and insertion of central monitoring lines.
 - Open individual Vent Valves (on the seven Torso cells, four Thigh cells and five **Heelguard** cells) to allow single cell deflation to assist with pressure area care and patient management, including everyday interventions such as CXR imaging.

WARNING

Vent Valve Restrictions. For periods longer than 10 minutes, have no more than 4 cells deflated at any one time (excluding the three cells in the Head Section).

6. Decontamination

The following guidelines have been established in accordance with good infection control practice.

Should you have any questions regarding cleaning or if you require further information please contact your Huntleigh Healthcare service centre.

WARNING

Remove the electrical supply to the pump by disconnecting the mains power cord from the mains power supply before cleaning.

Protective clothing should always be worn when carrying out decontamination procedures.

Caution

Do not use Phenol-based solutions or abrasive compounds or pads during the decontamination process as these will damage the surface coating.

Avoid immersing electrical parts in water during the cleaning process.

During Use It is recommended that, where practicable, all parts of the system (including mattress, mattress top cover, pump and tubeset) should be cleaned weekly whilst in use.

To Clean All parts should be cleaned in between each patient use, using a disposable cloth soaked in neutral detergent and warm water.

Dry all parts thoroughly using a disposable cloth.

To Disinfect After cleaning, wipe over all parts with a solution of sodium dichloroisocyanurate (NaDCC) to a dilution of 1,000 ppm of available chlorine.

If any part is visibly contaminated in liquid blood, increase the concentration of sodium dichloroisocyanurate (NaDCC) solution to a dilution of 10,000 ppm of available chlorine.

To Launder the Mattress Top Cover

The top cover on Huntleigh Healthcare mattresses is manufactured from one of the following three materials, each of which has different properties and laundering guidelines (refer to “Cover Options and Features” on page 32):

- Dartex (standard cover).
- Advantex.
- eVENT.

 *The **Nimbus 3 Professional** standard and narrow mattresses are available with all three top covers, but the **Nimbus 3** standard mattress is only available with the Dartex and Advantex top covers and the **Nimbus 3** narrow mattress is only available with the Dartex top cover.*

The following laundering guidelines apply to all three top cover materials, unless otherwise stated:

1. To achieve thermal disinfection, the temperature in the washing cycle of the laundering process must be maintained at:
 - 71°C for a minimum of 3 minutes, or
 - 65°C for a minimum of 10 minutes.

 *This data is based on the United Kingdom Health Service Guideline HSG(95)18.*

2. The top cover is then dried as follows:
 - The Dartex and eVENT covers can be tumble dried up to 85°C or air dried.
 - The Advantex cover must be tumble dried **ONLY**. The tumble drying temperature must be between 80 and 85°C.

 *After each wash cycle, in order to reactivate the fluorocarbon coating on the surface of the Advantex material (to prevent wetting), the Advantex cover must be tumble dried at a temperature of between 80 and 85°C.*

3. The life spans of the different cover materials are:
 - A minimum of 50 wash cycles for Dartex and Advantex.
 - 15 wash cycles for eVENT.

 *The life span of the eVENT cover is significantly lower due to the inherent nature of the eVENT material.*

7. Routine Maintenance

Nimbus 3 and Nimbus 3 Professional Systems

Maintenance The equipment has been designed to be virtually maintenance-free between service periods.

Servicing Huntleigh Healthcare will make available on request service manuals, component parts lists and other information necessary for Huntleigh Healthcare trained personnel to repair the system.

Service Period It is recommended that the pump is serviced every 12 months by a Huntleigh Healthcare authorised service agent.

The “telephone” symbol  will be illuminated on the pump front panel to indicate that the pump is ready for a service (Refer to “Service Indicator” on page 13).

Nimbus 3 Pump

General Care, Maintenance and Inspection Check all electrical connections and the mains power cord for signs of excessive wear.

Test the Power Fail Alarm before use (Refer to “Testing the Power Fail Alarm” on page 15).

In the event of the pump being subjected to abnormal treatment, e.g. immersed in water or dropped, the unit must be returned to an authorised service centre.

Biofilter The internal biofilter can be run continuously for two years before it requires autoclaving or replacement.

The biofilter can only be replaced by a service engineer.

Nimbus 3 and Nimbus 3 Professional Mattresses

General Care Remove the cover from the mattress.

Inspect the cover for signs of wear or any tears, and check that all cover fasteners are secure.

Check the security of all internal connections, including:

- Between the cells and the manifold.
- To the CPR/Transport Controls.
- To the Head Section Deflate Control on the **Nimbus 3 Professional**.

Make sure all cell fasteners are correctly connected to the mattress base sheet and are not loose or damaged.

Serial Number Labels



Pump The serial number label for the pump is on the back of the pump case.

Mattress The serial number label for the mattress is on the top of the CPR/Transport Control, on the outside of the mattress at the foot end.

8. Troubleshooting

The following table provides a troubleshooting guide for the **Nimbus 3** and **Nimbus 3 Professional** systems in the event of malfunction.

 Refer to Section 4, Page 11 “Controls, Alarms and Indicators” for a comprehensive description of the alarms and indicators on the pump.

Indicator	Possible Cause	Remedy
LOW PRESSURE and WAIT .	<ol style="list-style-type: none"> The pump is inflating the mattress. CPR control not fully closed. 	<ol style="list-style-type: none"> Both indicators will extinguish when the operating pressure is reached. Close CPR control.
LOW PRESSURE .	<ol style="list-style-type: none"> The tubeset is not connected properly. CPR control not fully closed. The Transport control on the mattress is set to TRANSPORT. There is a leak in the system 	<ol style="list-style-type: none"> Check the tubeset connectors and make sure they are securely connected to the pump and mattress. Close CPR control. Turn the Transport control to NORMAL. Call the service engineer.
HIGH PRESSURE .	<ol style="list-style-type: none"> The tubeset is blocked. The AutoMatt sensor pad is blocked. 	<ol style="list-style-type: none"> Check that the tubeset is not kinked. Check that the AutoMatt sensor pad is flat and not kinked.
Flashing POWER and  symbol.	<ol style="list-style-type: none"> Power Fail Alarm.^(a) The pump has detected that mains power has been removed. 	<ol style="list-style-type: none"> Re-apply mains power or switch off the pump using the POWER switch on the control panel. If power failure is prolonged, switch to TRANSPORT mode and disconnect the tubeset. The mattress will remain inflated for 12 hours.
Flashing PUMP FAULT and  symbol.	<ol style="list-style-type: none"> Internal pump malfunction. 	<ol style="list-style-type: none"> Call the service engineer.
 symbol.	<ol style="list-style-type: none"> The pump needs a service.^(b) 	<ol style="list-style-type: none"> Call the service engineer.
Mattress cells will not inflate (Nimbus 3 Professional only).	<ol style="list-style-type: none"> Vent Valves are open. 	<ol style="list-style-type: none"> Close Vent Valves.

a. If the pump has not been used for a long period, the internal battery which provides the Power Fail Alarm indication may be discharged. Run the pump for a few hours to recharge the internal battery, and the Power Fail Alarm indication will be provided as normal. To check that the Power Fail Alarm is operating correctly, refer to “Testing the Power Fail Alarm” on page 15.

b. The service period is set to 12 months.

Fuse Replacement If the system fails to operate when plugged in and switched on, the two fuses situated above the mains power cord on the pump should be checked. To do this, disconnect the pump from the main power supply and remove each fuse holder cap using a suitable flat-bladed screwdriver.

Caution

To protect against fire hazard, replace blown fuses only with the identical type and rating (Refer to Section 10, Page 29 “Technical Description”).

If either fuse blows again contact a service engineer or suitably qualified personnel.

9. Warranty and Service

Huntleigh Healthcare's standard terms and conditions apply to all sales. A copy is available on request. These contain full details of warranty terms and do not limit the statutory right of the consumer.

Huntleigh Healthcare recommend that the **Nimbus 3** and **Nimbus 3 Professional** systems should be serviced every 12 months.

For service, maintenance and any questions regarding this, or any other Huntleigh Healthcare product, please contact:

Huntleigh Healthcare Pty Ltd

78 Forsyth Street

O'Connor, WA 6163

Freecall 1800 072 040

PH: 61 (0)8 9337 4111

FX: 61 (0)8 9337 9077

or your local distributor.







10. Technical Description

Pump	151028
Supply Voltage:	230 Vac
Supply Frequency:	50 Hz
Electrical Rating:	35 VA
Size:	Length: 508 mm (20 in.)
	Height: 220 mm (8.7 in.)
	Depth: 100 mm (4 in.)
Weight:	5.7 kg (12.5 lb.)
External Fuse Rating:	2 x F 500 mA, 250 V
Operating Cycle	10 minutes

UK and Euro Electrical Safety Standards

Complies with:	EN 60601-1:1990/A13:1996
Degree of protection against electric shock:	Class I, Type BF
Degree of protection against liquid ingress:	IPx0
Mode of operation:	Continuous

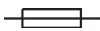
Pump Symbols

	Alternating Current
	Switches the mains power to the pump OFF
	Switches the mains power to the pump ON
	Type BF
	Fuse
	Refer to product manual

Environmental Conditions

Operating

Temperature range:	+10°C to +40°C
Relative humidity:	30% to 75%
Atmospheric pressure	700hPa to 1060 hPa

Storage

Temperature range:	-40°C to +70°C
Relative humidity:	10% to 100% (non-condensing)
Atmospheric pressure:	500 hPa to 1060 hPa

Environmental Protection: Please dispose of this unit in accordance with local regulations.

Tube Set	151200	151201
Length:	1000 mm (39.4 in.)	2500 mm (98.4 in.)
Material: Tube:	5-way moulded PVC	
Connectors:	Moulded Nylon	

Nimbus 3 Mattress

Part Numbers:	Standard Width	Narrow Width
Standard Cover	152010DAR	237010
Advantex[®] Cover	152010ADV	(not applicable)
Size: Length:	2085 mm (82 in.)	
Height:	215 mm (8.5 in.)	
Width:	890 mm (35 in.)	800 mm (31.5 in.)
Weight:	11.5 kg (25.3 lb.)	10.3 kg (22.7 lb.)
Cell Material:	Polyurethane	
Base Material:	PU Coated Nylon	
Top Cover Material:	PU Coated Fabric or Advantex	PU Coated Fabric

Nimbus 3 Professional Mattress

Part Numbers:	Standard Width	Narrow Width
Standard Cover	412001DAR	412201DAR
Advantex [®] Cover	412001ADV	412201ADV
eVENT [®] Fabric Cover	412001EVE	412201EVE
Size: Length:	2085 mm (82 in.)	
Height:	215 mm (8.5 in.)	
Width:	890 mm (35 in.)	800 mm (31.5 in.)
Weight:	15.5 kg (25.3 lb.)	14.3 kg (22.7 lb.)
Cell Material:	Polyurethane	
Base Material:	PU Coated Nylon	
Top Cover Material:	PU Coated Fabric or Advantex or eVENT Fabric	

Cleaning Symbols



Do not use phenol-based solutions



Do not iron



Use solution diluted to 1000 ppm of available chlorine

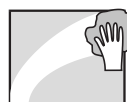

Wipe surface with damp cloth



Tumble dry at a cool setting



Tumble dry at 80-85°C



> 3 min

Wash at 71°C for a minimum of 3 minutes



> 10 min

Wash at 65°C for a minimum of 10 minutes

Cover Options and Features

Feature	Standard Cover (Dartex) [®]	Advantex [®]	eVENT [®] Fabric ^(a)
Removable Cover	Yes	Yes	Yes
Moisture Vapour Permeable	Yes	Yes	12 times higher
Air Permeable	No	No	Yes
Low Friction	Yes	18% lower	20% lower
Water Resistant / Repellent	Yes	Yes	Yes
Infection Control	Bacteriostatic, fungistatic, antimicrobial	Bacteriostatic, fungistatic, antimicrobial	INERT MATERIAL does not support bacterial growth
Fire Retardant	BS 7175: 0,1 & 5	BS 7175: 0,1 & 5	BS EN ISO 12952-1 ONLY ^(a)
2-Way Stretch	Yes	Some	No
Washing Conditions ^(b)	71°C for 3 minutes or 65°C for 10 minutes	71°C for 3 minutes or 65°C for 10 minutes	71°C for 3 minutes or 65°C for 10 minutes
Drying Conditions	Tumble Dry up to 85°C or Air Dry	Tumble Dry ONLY at 80-85°C	Tumble Dry up to 85°C or Air Dry
Life Span	50 Wash Cycles (minimum)	50 Wash Cycles (minimum)	15 Wash Cycles
Application Area	Acute and Homecare	Acute and Homecare	Acute ONLY ^(a)

a. Due to the inherently lower flame retardancy of the high performance eVENT[®] fabric, it is **NOT** suitable for use in the homecare environment.

b. Washing conditions are based on the United Kingdom Health Service Guideline HSG(95)18.



Huntleigh
HEALTHCARE

HUNTLEIGH HEALTHCARE LIMITED

310-312 Dallow Road, Luton,
Bedfordshire, LU1 1TD, United Kingdom

T: +44 (0)1582 413104 **F:** +44 (0)1582 459100

Sales Enquiries **T:** +44 (0) 1582 745700 **F:** +44 (0)1582 745745

Service Enquiries **T:** +44 (0)1582 745777 **F:** +44 (0)1582 745869

Huntleigh Rentals 24 Hour Helpline **Lo-call** 08457 342000

W: www.huntleigh-healthcare.com

Registered No: 942245 England. Registered Office As Above
© Huntleigh Healthcare Ltd 1998



93/42/EEC



943447

© and ™ are trademarks of Huntleigh Technology PLC

As our policy is one of continuous improvement, we reserve the right to modify designs without prior notice.

GENLIT004A_03

151996AU_02