



Huntleigh
HEALTHCARE

Alpha Relief™



User Manual

CONTENTS

Introduction	1
Clinical Applications	4
Installation.	5
CPR Facility	7
Patient Transport	8
Controls, Indicators, and Alarms	9
Cleaning, Deflation and Storage	10
Troubleshooting Guide	11
Warranty and Service	12
Technical Data	13

Safety

Before you connect the system pump to a mains socket, read carefully all the installation instructions in Section 3 – Installation.

The system has been designed to comply with regulatory safety standards including:

- BS5724, Part 1
- IEC601-1
- VDE 0750 : Teil 1
- UL 2601-1 CAN/CSA C22.2 No: 601

For your own safety and the safety of the equipment always take the following precautions:

- Keep the pump away from sources of liquids
- Do not expose the system, especially the mattress, to naked flames, such as cigarettes etc.
- Do not store the system in direct sunlight
- Do not use hypercarbonate and phenolic based cleaning solutions
- Keep sharp objects away from the mattress
- Ensure that the system is clean and dry prior to storage
- Store the pump and mattress in the protective bags supplied
- We recommend the use of cot sides on the bed while the system is in use and the patient is positioned on top. Local policies regarding the use of cot sides should be taken into account.
- Keep these instructions handy for reference

WARNINGS

The cover of this product is non air permeable and may present a suffocation risk. It is the responsibility of the carer to ensure that the user can use this product safely.

Do not use the *Alpha Relief* pump in the presence of flammable gases such as anaesthetic agents.

Possible explosion hazard if used in the presence of flammable anaesthetics.

1. Introduction

The **Alpha Relief™** system is an alternating pressure relief system which consists of a pump and mattress replacement.

The system can be used on standard hospital and normal domestic beds. Beds can be adjusted or gatched with the **Alpha Relief** system in position.

Product Description

Alpha Relief Mattress Replacement

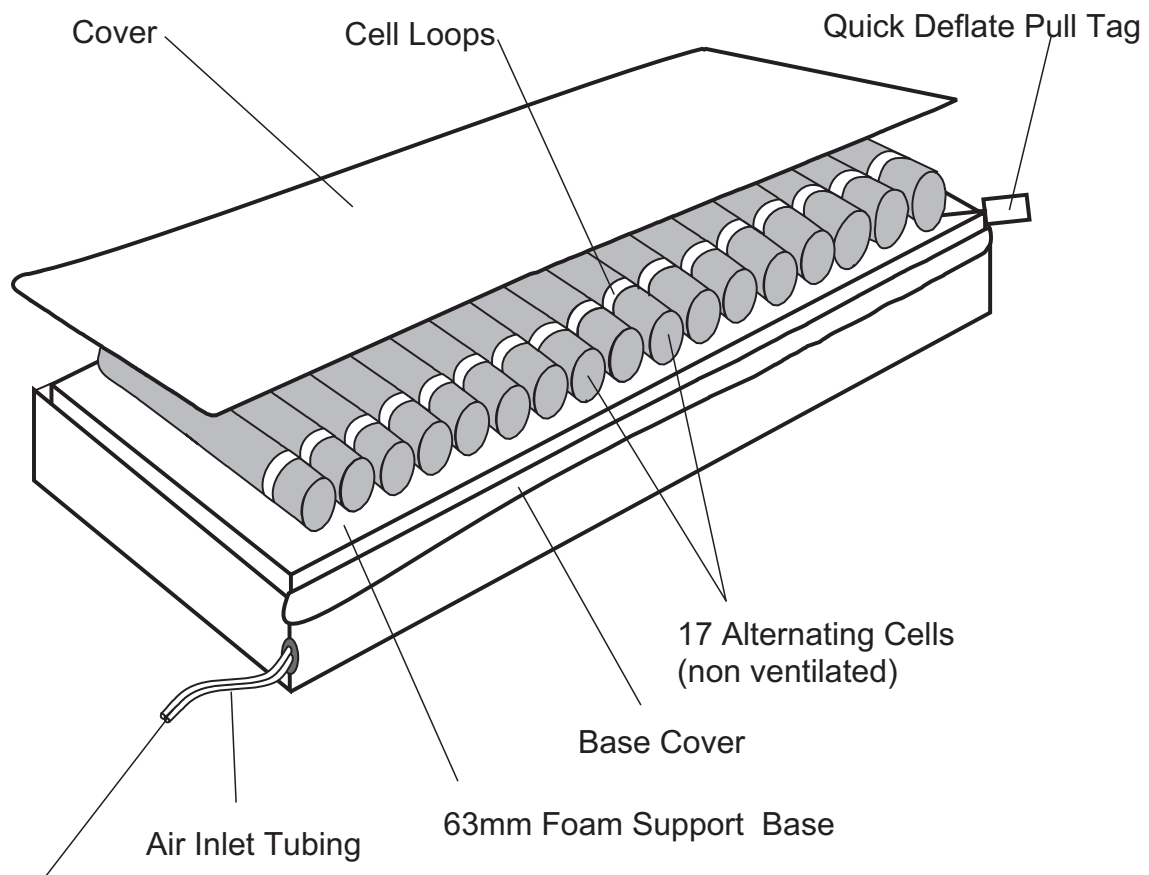

Tubing Connectors

Cells

Seventeen polyurethane (PU) cells providing alternating support to the user.

Quick Deflate Pull Tag

A Quick Deflate Pull Tag is located at the head end to allow for CPR and quick deflation of the mattress following use.

Tube Set

Made from materials which reduce the risk of accidental kinking of the tubing.

Tube Connectors

Located at the foot end of the tubing set are specially designed male and female snap-lock connectors. This particular design helps prevent accidental disconnection of the mattress from the pump.

Detachable Cover

The protective cover comprises a two-way stretch top cover (ARC80) zipped to a durable nylon base (ARB80). The zips are protected by a flap to prevent ingress of contaminants and allow easy removal of the top cover for cleaning.

Foam Base

This is a 63mm thick base made of fire-retardant foam.

Alpha Relief Pump

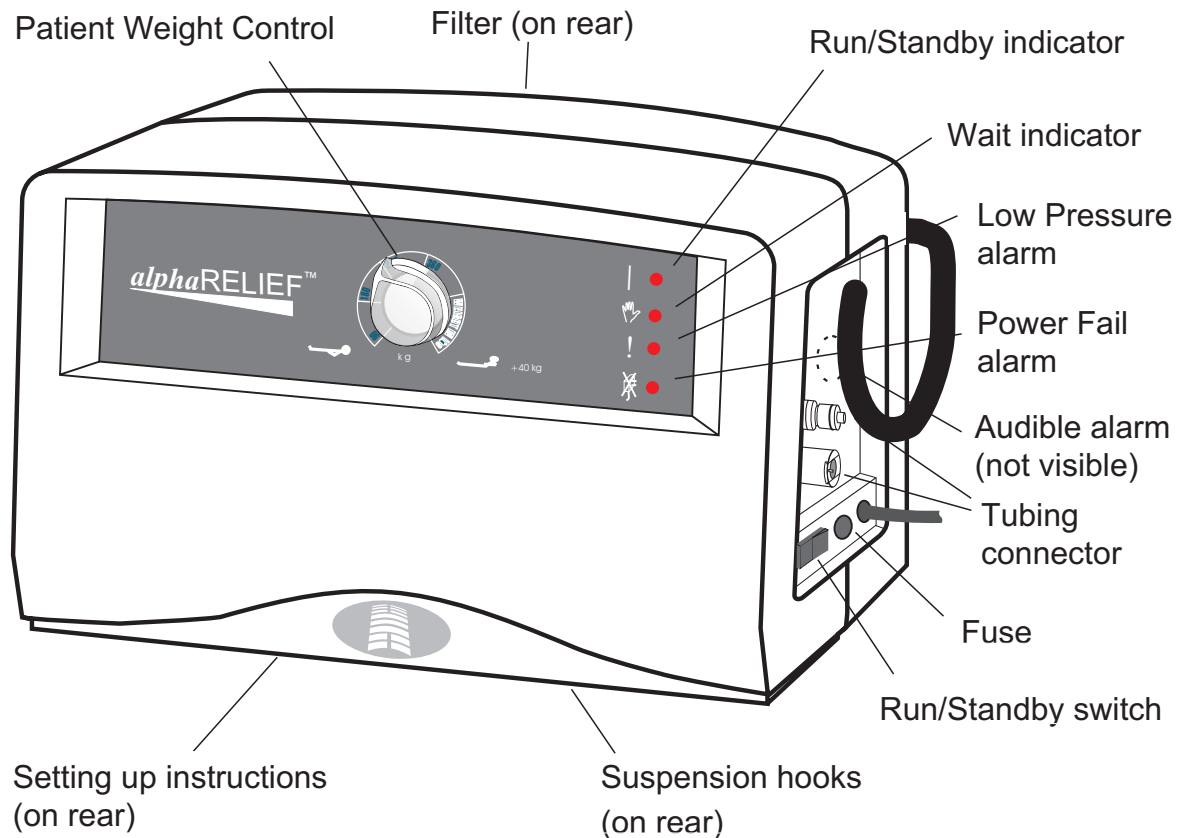

The pump has a tough outer case, with non-slip feet situated on the base and on the back.

Mounting Hook

The hook allows easy positioning of the pump on the bed frame.

Low Pressure Alarm Light

Situated on the front of the pump, the red low pressure alarm light illuminates when the pressure within the mattress is too low, indicating a possible low pressure fault or that the system is initially inflating. It will go out once the system is fully inflated, indicating that the system is ready for use.

Pressure Setting Control

Located on the front of the pump, this manual pressure setting control dial is used in conjunction with the Patient Weight Guide. It provides the means for adjusting the pressure inside the mattress.

2. Clinical Applications

Indications The **Alpha Relief** system is indicated for patients up to 160kg with a medium to high risk of developing pressure ulcers or with existing pressure ulcers up to and including grade 2 (EPUAP, 1998)¹.

Contraindications The **Alpha Relief** system should not be used for patients with unstable spinal fractures.

In the case of patients with other unstable fractures, where a moving surface could be harmful, advice should be obtained from the appropriate physician before using the **Alpha Relief** system.



*The **Alpha Relief** system is an aid to the prevention and management of pressure ulcers. If there is no improvement in the patient's condition, specialist advice should be sought.*

The above are guidelines only and should not replace clinical judgement or experience.

¹ European Pressure Ulcer Advisory Panel (1998). Pressure Ulcer Treatment Guidelines, British Journal of Nursing 7(5):888-9.

3. Installation

Preparing the Pump and Mattress Replacement System for Use

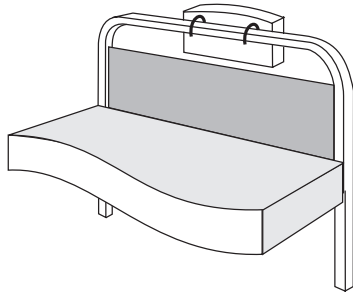

The system is very simple to set up using the following guidelines.

1. Remove the system from the carry bag.
2. Plug the pump power cord into the electrical outlet. Leave the Run/Standby switch in the Standby position.
3. The pump should be placed feet down on any convenient surface or alternatively suspended from the bed foot rail by means of the swing out hooks.
4. Place the **Alpha Relief** mattress replacement directly on the top of the bed frame with the air feed tubes located near the pump at the foot of the bed and cell structure uppermost.

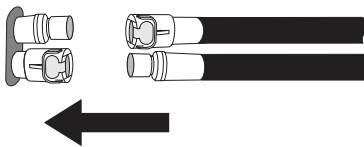
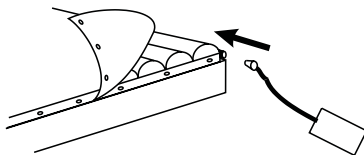

WARNING

Never use sharp objects or electrically heated underblankets on or under the mattress replacement.



5. Ensure that the rapid deflate plug at the head-end is securely inserted.
6. Ensure that the protective cover is over the cell assembly and is fixed into position, smooth coating on outside. This will reduce the risk of the cell assembly becoming contaminated.
7. Connect male and female air feed tubes to appropriate air outlets on the pump unit, ensuring that the tubes are not “kinked” or twisted. Push the connectors in until they click.
8. Switch on the pump unit. All lights on the front panel will momentarily flash. The Run/Standby and Wait indicators will remain illuminated.
9. Allow approximately 25 minutes for the pad to inflate fully. The amber Wait indicator will go off once the pad is fully inflated.

10. Place a bed sheet over the mattress replacement and tuck in loosely without wrinkles.
11. Adjust the patient weight control for the appropriate patient weight. Increase the weight by 40kg. when the patient is in the sitting position.

Patient Weight	
	
60kg	+40kg
80kg	+40kg
120kg	+40kg
160kg	+40kg



We recommend that this product be used with a pillow to enhance comfort.

WARNINGS

The weight guide on the pump is only an indication and should not replace clinical judgment.

Ensure that the patient is not bottoming out by sliding a hand between the inflated cells on top of a deflated cell underneath the patient's heaviest point; e.g. buttocks. The correct amount of 'lift' is achieved when two fingers can be easily slid underneath. If only the flat hand can be slid under, then more support is required. Increase the pressure control slightly, wait 10 minutes and check again, adjusting if necessary. If more than two fingers can be slid underneath, i.e. three fingers depth, there is too much support. Decrease the pressure control, wait 10 minutes and check again, adjusting if necessary.

Alignment of bed frame, bedside rails and mattress should leave no gap wide enough to entrap a patient's head or body. Care should be exercised to prevent occurrence of gaps by compression or movement of the mattress. Death or serious injury may result.

4. CPR Facility

Important

In the event of a cardiac arrest, pull the Rapid Deflate tag firmly at the head end of the mattress and disconnect the tubeset connectors at the pump. CPR may be started immediately while the mattress is deflating.

CPR

Located at the head end of the pad (on the same side as the tubing set) is a tag labelled **Rapid Deflate**. In the event of cardiac arrest, pull this tag for mattress deflation.

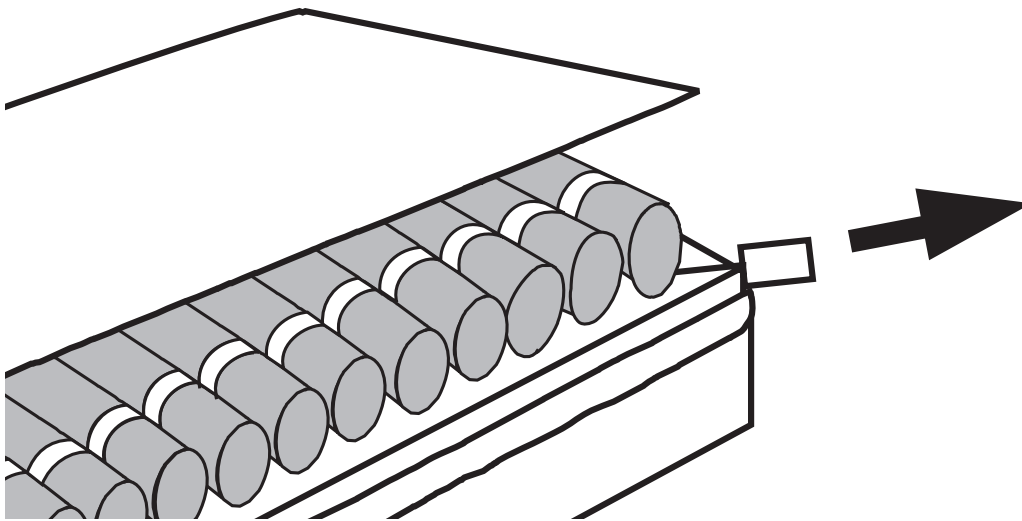

To reinflate the mattress, simply replace the stopper securely, locking connectors onto the manifold and ensuring secure connection of the mattress to the pump.



Ensure that the pump is connected to the power supply and switched on.

5. Patient Transport

The patient may be transported on the **Alpha Relief** mattress by disconnecting the tubes from the pump and cross connecting them immediately.

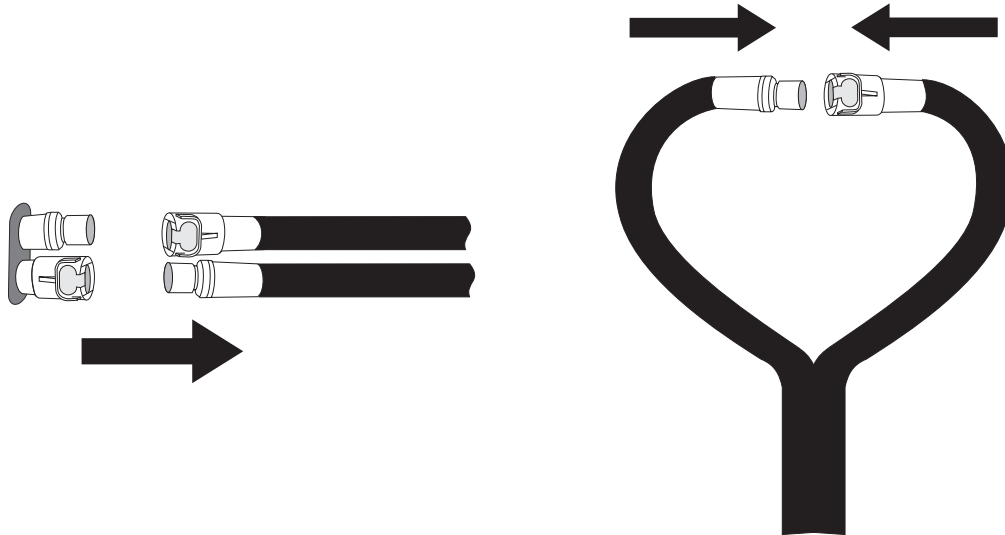

The pressure in the two sets of cells will equalise and the patient will continue to be supported (with the mattress static) for up to eight hours with the patient in the supine (lying) position.



To obtain the maximum use of the transport facility ensure that the patient remains in the supine position and the mattress is put in transport mode during cell crossover period.

6. Controls, Indicators, and Alarms

Controls

Pressure Control

This is situated on the front panel and is adjusted by the carer to suit the weight of the patient.

Run/Standby Switch

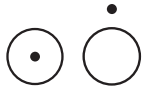

This is situated on the side panel of the pump and is used to activate the unit and reset the alarm. Mains isolation should be performed by switching the pump to standby (○) and then removing the mains plug from the socket.

Indicators



A light on the front panel indicates that the pump is running.



When the mattress is being inflated the amber Wait indicator will remain illuminated until the mattress is correctly inflated.

Low Pressure

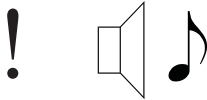

In the event of low pressure in the mattress, the red

Low Pressure Alarm will start flashing and an audible alarm will sound. The pitch of the alarm will increase at 60 second intervals.

Mains Fail

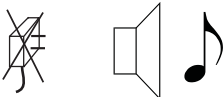

In the event of mains failure, the red alarm indicator will start flashing and an audible alarm will sound. The pitch of the alarm will increase in time. If the power supply is returned the audible alarm will stop, but the alarm light will remain illuminated until the system is reset (UK only).

Alarm

Alarm Reset

When the cause of the alarm has been resolved, the pump needs to be reset. This can be achieved by switching the pump to Standby and back to Run using the Run/Standby switch on the side panel.

Self Test

Every time the pump is switched on all indicator lights will illuminate for approximately two seconds. During this period, the system self tests its circuits.

7. Cleaning, Deflation and Storage

Cleaning

Huntleigh Healthcare products are manufactured to the highest quality standards. It is therefore important to follow the specified cleaning instructions.

Caution

Do not use phenol based cleaning solutions.

Mattress

The mattress can be cleaned while on the bed using hot water and a mild household detergent. If the mattress is soiled, it can be wiped down using a 1,000 ppm sodium hypochlorite solution, sodium dichloroisocyanurate solution (NaDCC) or any other non-phenolic, hospital grade disinfectant. The top cover must be dry prior to use.

The cover can be washed and thermally disinfected in a washing machine. Recommended maximum temperature is 80°C.

Pump

WARNING

Switch off the electrical supply to the pump and disconnect the power cord from the mains supply before cleaning and inspection.

The pump casing should be cleaned using a soft cloth dampened with a mild household detergent. If the pump is heavily soiled (i.e. blood spillage, urine, etc.), the pump can be wiped down with a 1,000 ppm hypochlorite solution.



For complete laundering instructions refer to Huntleigh Healthcare Infection Control guidelines, Class A equipment category.

Deflation and Storage

To deflate the mattress, switch the pump off and disconnect from power supply. Disconnect the tube connectors by pressing the metal snap lock connectors and pull the male and female connectors apart. Pull the Rapid Deflate tag. All the air in the mattress will now be expelled. Starting at the head end, the mattress can now be rolled or folded for storage.

8. Troubleshooting Guide

WARNING

Electrical equipment may be hazardous if misused. The pump's case back should only be removed by authorised technical personnel.

Problem	Possible Cause	Action
Mattress not inflating.	1. Rapid Deflate stopper not inserted. 2. Tubes kinked. 3. Pump not switched on. 4. No pump output. 5. Tubes not correctly fitted.	Check Check Check Check. See <i>Pump not operating</i> below Check
Consistent Low Pressure Alarm.	1. Rapid Deflate stopper not inserted. 2. Tubes not correctly fitted. 3. Leakage.	Check Check Check
The Wait indicator does not go off	Rapid Deflate stopper not inserted. Tubes not correctly fitted. Leakages	Check Check Check
The Mains Fail indicators (audible and visual) are active.	1. A mains power failure has occurred. 2. The power cord has been removed from the wall socket	Check Check
The Mains Fail indicator remains constantly illuminated but there is no audible alarm.	There has been a mains power failure but power has been restored (UK only).	Check if electrical plug is correctly fitted, and if pump is running correctly.
Pump makes a lot of noise and/or is causing lot of vibration.	System damaged or dirty.	Call Service Engineer for maintenance.
Pump not operating	1. Pump Run switch not on. 2. Plug not inserted correctly. 3. Fuse Blown. 4. Technical failure.	Switch on Check Replace with same type and rating. Call Service Engineer for maintenance.
All indicators remain illuminated on initial switch-on.	Internal fault.	Call Service Engineer for maintenance.



Ensure pump alarms are reset by operating the Run/Standby switch after the fault has been corrected.

9. Warranty and Service

Huntleigh Healthcare's standard terms and conditions apply to all sales. A copy is available on request. These contain full details of warranty terms and do not limit the statutory right of the consumer.







For service, maintenance and any questions regarding this, or any other Huntleigh Healthcare product, please contact:

Huntleigh Healthcare Ltd
310-312 Dallow Road
Luton
Bedfordshire, LU1 1TD

Tel : 01582 413104
Fax : 01582 459100

or your local distributor.

10. Technical Data

Pump Model Number:	ALR01
Size:	248 x 160 x 116 mm
Weight:	2.75 kg
Cycle Time:	10 minutes
Rated Voltage:	220-240V
Rated Frequency:	50Hz
Rated Input Power:	14 VA
Protection Class:	Class II, type BF  Not protected against the ingress of water.
Equipment Symbols:	 Indicates unit is Class II double insulated against electric shock.  Refer to user manual. REF: Model number SN: Serial number  Alternating current  Standby. Note: unit is not isolated from mains supply!  Run  Fuse, rated F500mA
Rated For:	Continuous consumption
Tested To:	BS5724 : Part 1 IEC 601-1 V.D.E. 0750: Teil 1

Environmental Conditions

Operating

Temperature range:	+10°C to +40°C
Relative humidity:	30% to 75%
Atmospheric pressure:	700hPa to 1060hPa

Storage

Storage temperature range:	-40°C to +70°C
Relative humidity:	10% to 100% (non-condensing)
Atmospheric pressure:	500hPa to 1060hPa
Environmental Protection:	Please dispose of this unit in accordance with local regulations.

Mattress

Mattress Model No.:	402001
Size:	209cm x 86cm (81½ x 33 inches)
Inflated Cell Height:	13.3cm (5.1 inches)
Inflated Mattress Height:	19.1cm (7½ inches)
Foam Base Size:	2032 x 838 x 63.5 mm (80 x 33 x 2½ inches)
	Polyurethane foam. Combustion-modified, high resilience to schedule 1, Part 1 Furniture and Furnishings (Fire & Safety Regulations) 1988 (amended 1989). Fatigue Class 5.
Cell Material:	Polyurethane
Cover:	ARC80/ARB80 (cover and base) Material: PU coated nylon, flame retardant to BS7175/BS5852.
Carry Bag:	402067

Cleaning Symbols:



Wash at 80° C



Do not iron



Do not use phenol-based products

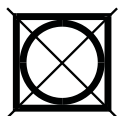

Do not tumble dry

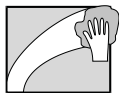

Wipe surface with damp cloth



1000ppm
NaOCl
NaDCC

Use solution diluted to 1000ppm



Huntleigh

HEALTHCARE



A Pyramid of Care® Product

Huntleigh Healthcare Ltd. A Huntleigh Technology PLC Company
310-312 Dallow Road, Luton, Bedfordshire, LU1 1TD
Telephone: 01582 413104 Fax: 01582 459100

Sales Enquiries Telephone: 01582 745700 Fax: 01582 745745

Huntleigh Rentals 24 hour Helpline **Lo-call 08457 342000**

Website: www.huntleigh-healthcare.com E-mail: sales.admin@hunhcare.co.uk

® and ™ are trade marks of Huntleigh Technology PLC.

As our policy is one of continuous improvement, we reserve the right to modify designs without prior notice.



943447

Registered No: 942245 England

© Huntleigh Technology PLC 1998



93/42/EEC

500972EN/01

GENLIT004A/01